

Road Force® Elite GSP9700 Series Wheel Balancer

Operation Instructions

Version 3



HUNTER
Engineering Company®

Copyright © 2016-2019 Hunter Engineering Company

OWNER INFORMATION

Customer Name: _____ Installation Date: _____

Model Number: _____ Serial Number: _____

Order Number: _____ Software Number: _____

Sales Representative Name and Number: _____

Sales Representative Phone: _____

Service and Parts Representative Name and Number: _____

Service and Parts Representative Phone: _____

Hunter Wheel Balancer - Equipment Training Report

Technicians Trained: *Please Print*

Technician 1: _____ Technician 2: _____

Technician 3: _____ Technician 4: _____

Please have trained technicians initial each training item:

<u>Balancer Training Task</u>	<u>Tech 1</u>	<u>Tech 2</u>	<u>Tech 3</u>	<u>Tech 4</u>
Safety Precautions, Power On/Off Procedures				
Overview of Display, Dataset Arms, Spindle Pedal & Wheel Lift				
Inflation Station and Bar Code Operation (if applicable)				
Mounting Methods (Front-Cone, Back-Cone, Flange Plate)				
Clamping (Quick Thread/Auto Clamp) Operation				
Centering Check Procedures				
Balance Mode Selection (Balance Only, Road Force, Straight Trak)				
Weight Location Entry (Clip-Clip, Clip-Tape, Tape-Tape, Split-Spoke)				
Installation of Wheel Weights (Servo-stop, Hammerhead, BDC Laser)				
Recalling TPMS Reset Procedures				
Performing a Balancer Calibration/Calibration Check				
Rim Runout Measurement (Rim with Tire, Bare Rim)				
Match Mounting				
Tire Stack Operation				
Printout Selection				

Installation & Training Acknowledgement: I, the undersigned, do hereby acknowledge that my Hunter Engineering Wheel Balancer has been installed and is operational. I also acknowledge that the above technicians have been trained to my satisfaction in those areas of safety and operation as indicated above.

Management Name (print): _____

Date: _____

Management Signature: _____

Contents

Owner Information	v
1. Getting Started	7
1.1 Introduction	7
Corporate Information	7
References	7
1.2 For Your Safety	8
Hazard Definitions	8
IMPORTANT SAFETY INSTRUCTIONS	8
SAVE THESE INSTRUCTIONS	9
Electrical	9
Decal Information and Placement	9
Right Side View	9
Front View	10
Left Side View	10
Back View	11
Specific Precautions/Power Source	11
Specific Precautions/Optical Scan Laser	12
Specific Precautions/HammerHead® TDC Laser Indicator (Optional)	12
Turning Power ON/OFF	12
Push Button Switch	12
Main Power Switch	12
Equipment Installation and Service	13
Equipment Specifications	13
Explanation of Symbols	13
1.3 Road Force® Elite Main Screen Components	14
1.4 Road Force® Elite Components	15
1.5 Operating the Balancer	16
Main Balance Screen	16
Main Balance Screen - Error Pop-ups	16
Main Balance Screen - Tire Rash	16
Main Balance Screen - Prompt Text	16
Main Balance Screen – Enable and Disable Load Roller	17
Main Balance Screen – Inflation Station	17
Main Balance Screen – Performing a Spin	17
Main Balance Screen – Servoing To Position	18
Main Balance Screen – Road Force® Buttons	19
Main Balance Screen – SmartWeight® Buttons	19
Secondary Screens - Print Screen Button	19
2. Introduction to Balancing	21
2.1 Balance Forces	21
Balancing Theory - Static Imbalance	21
Balancing Theory - Couple Imbalance	22
2.2 SmartWeight® Balancing Technology	23
Static and Dynamic Imbalance Sensitivity	23
2.3 SmartWeight® Balancing Technology Dynamic Weight Planes	24
2.4 Using SmartWeight® Balancing Technology	24
Switching from SmartWeight® Balancing Technology to Traditional Dynamic Balancing	25
Switching from Traditional Dynamic Balancing to Traditional Static Balancing	26
Blinding and Rounding	26
Enable Performance Mode	26
Show Savings	26
Road Force® Savings	27
3. Balancing Procedures	31
3.1 Mounting a Wheel Using Wheel Lift (Optional)	31

Raising the Wheel Assembly	31
Lowering the Wheel Assembly	32
3.2 Mounting the Wheel on the Balancer Spindle Shaft	33
Installing the Wheel - Typical Scenario	33
Installing the Wheel Using Quick-Thread® Wheel Clamping	34
Installing the Wheel Using SpeedClamp™ Wheel Clamping (Optional)	35
3.3 CenteringCheck® Wheel Centering Feature.	37
CenteringCheck®	37
CenteringCheck® Errors	37
Using CenteringCheck®	37
Mounting Error Detection Features	38
3.4 Front / Back Collet Mounting	39
Using The Plastic Wheel Mounting Spacer	39
Using The 9-Inch Alloy Wheel Pressure Cup	40
Front Collet Mounting	40
Heavy Wheel Centering	40
3.5 Specialized Mounting Conditions	41
Collet / Flange Plate Mounting	41
Expandable Collet Mounting	41
Using the Pressure Ring and Spacers	41
Pressure Ring	41
3.6 On-Vehicle Wheel Installation Methods	42
Hub Centric	42
Lug Centric	43
3.7 Wheel Assembly Selection for Saving Spin Data	43
Saving Spin Data	43
Measurement Storage	43
Print Summary	44
Single Assembly Road Force® Printouts	45
3.8 Balance Modes.	46
Dynamic Balancing – Traditional Balancing Mode	46
Switching from SmartWeight Balancing Technology® to Traditional Dynamic Balancing	46
Static Balancing – Traditional Balancing Mode	47
Switching from Traditional Dynamic Balancing to Traditional Static Balancing.	47
Blinding and Rounding	47
3.9 Balancing Procedures for Specific Weight Types and Placement using TruWeight™	48
SmartScan™ Dimensions Entry	48
Single Weight Placement	48
Balancing Procedure Using Clip-On Weights	48
Balancing Procedure Using a Combination of Clip-On & Adhesive (Tape) Weights (Mixed Weights)	50
Balancing Procedure Using Adhesive (Tape) Weights.	51
Enable Dragging Feature	52
3.10 Blinding and Rounding	53
3.11 Tape Weight Menu	53
Split Weight®	54
Correcting Large Imbalances	54
3.12 Split Spoke® Feature.	55
3.13 Optional HammerHead® TDC Laser Clip-On Weight Locator	55
Specific Precautions / HammerHead® TDC Laser System	56
3.14 TPMSpecs™ Feature	56
3.15 Hunter Help.	58
Video Player	58
Launch Help	59
4. Road Force Measurement® Procedures	61
4.1 Load Roller Operation.	61
Road Force® with Limits Enabled	62
4.2 Forcematching®	62
ForceMatch® - Display of Data	62
Forcematching® - No Runout	63
ForceMatch® Procedures	63

Match Codes	64
180 Matching	64
Encountering Forcematch® Prediction Errors.....	65
Do's and Don'ts of Road Force® Measurement	66
4.3 StraightTrak® LFM (Lateral Force Measurement).....	67
Performing a StraightTrak® LFM Procedure:	67
Disabling StraightTrak®.....	69
Vehicle Plan View.....	69
Net Tire Pull	69
Changing Tag Numbers.....	70
Forcing a Tire Onto the Tire Stack	70
Road Force®.....	71
Show Least Pull.....	71
Show Least Vibration.....	71
Printout	71
Inflation Pressure	72
Extra Info	73
4.4 Individual Lateral Force Measurement.....	73
4.5 Inflation Station.....	75
4.6 Quick-Thread® Wheel Clamping.....	76
SpeedClamp™ Wheel Clamping (Optional).....	76
4.7 Motor Drive/Servo-Stop and Spindle-Lok®.....	77
Motor Drive/Servo-Stop	77
Spindle-Lok® Feature	77
4.8 Safety Hood Features	77
Hood Autostart	77
Auto Hood Feature	77
5. Equipment Information	81
5.1 Tools.....	81
Set Up.....	81
“Reset All” Button	82
Specification Database	82
Display Language	83
Print Language	83
Printer	83
Print Preview	83
Printout Paper Size Selection	83
Selectable Print Destination	83
Hood Autostart Feature.....	84
Servo-Stop	84
Rim Interior Light	84
VIN Entry.....	84
Balance Checkspin	85
Steering Wheel Location in Wheel Assembly Location.....	85
Weight Units	85
Support of 3M Tape Weights.....	85
Runout Units	86
Load Roller	86
Road Force® Units.....	86
TranzSaver™ Measurement	86
TranzSaver™ Implementation	86
Clear Tire Stack.....	87
Rim Dimension Manual Entry - Tape/Tape	87
Rim Dimension Manual Entry - Clip/Clip	88
Auto Hood	89
Background Color	89
Volume Control	89
Date and Time.....	89
Wheel Slip Detection.....	90
Calibration Procedures.....	90

Diagnostics	90
Identify Software and Autorization	90
Maintenance History	91
TPMS	91
Balance Bare Rim	92
5.2 USB Program Flash Drive and Security Key Removal and Installation	93
6. Calibration and Maintenance	95
6.1 Calibration Procedures	95
eCal™ Auto-Calibration	95
Calibration Procedures	95
Calibration Check	96
6.2 Diagnostic Tools	96
Data Acquisition Circuits	96
Switches	97
eCal™	97
Force Sensors	97
Spindle Encoder	98
Loaded Runout Sensor	98
6.3 Cleaning the Console	99
Cleaning the Screen	99
Safety Instructions	99
Spindle Hub Face and Shaft	99
Optical Scan Rim Measurement Maintenance or Service	99
Optional HammerHead® TDC Laser Clip-On Weight Locator Maintenance or Service	99
6.4 Mounting Collet Maintenance	100
6.5 Maintenance Schedule	101
7. Theory of Operation	103
7.1 Harmonic Vibrations	103
7.2 Road Force® and Runout Measurement	104
Force Variation	104
Tire Radial Force Variation (Uniformity)	105
7.3 Radial Force Variation (RFV)	105
What is Road Force Measurement® ?	105
Summarization:	106
7.4 Radial Force Variation vs. Unloaded Run Out	107
7.5 Road Force® Vibration Placed into Perspective	108
7.6 StraightTrak® Lateral Force Measurement System	108
StraightTrak® Lateral Force Measurement	108
Tire Pull Measurement and Correction	108
Theory	109
Conicity	109
Plysteer	110
Net Tire Pull	110
8. Glossary	111

OWNER INFORMATION

Customer Name: _____ Installation Date: _____

Model Number: _____ Serial Number: _____

Order Number: _____ Software Number: _____

Sales Representative Name and Number: _____

Sales Representative Phone: _____

Service and Parts Representative Name and Number: _____

Service and Parts Representative Phone: _____

Hunter Tire Changer - Equipment Training Report

Technicians Trained: *Please Print*

Technician 1: _____ Technician 2: _____

Technician 3: _____ Technician 4: _____

Please have trained technicians initial each training item:

<u>Training Task</u>	<u>Tech 1</u>	<u>Tech 2</u>	<u>Tech 3</u>	<u>Tech 4</u>
Safety Precautions/Power On/Off Procedures				
Filter/Oiler Maintenance				
Overview of Controls (Pedals, Switches, Levers)				
Table Top/Center Mount Height Adjustment				
Preparing Assembly (Air, Wheel Weights, TPMS Sensor)				
Wheel Lift Operation (if applicable)				
Bead Loosening with Side Shovel and/or Bead Rollers				
Normal and Reverse Drop Center Clamping Methods (flange plate)				
Cleaning and Lubricating During the Tire Changing Process				
Positioning the M/D Head and TPMS Sensor for Demounting				
Demounting the Upper and Lower Beads				
Positioning the TPMS Sensor for Tire Mounting				
Bead Press Arm Operation (if applicable)				
Mounting the Upper and Lower Beads				
Bead Seating/Tire Inflation				
Bead Massage Procedure				

Installation & Training Acknowledgement: I, the undersigned, do hereby acknowledge that my Hunter Engineering Tire Changer has been installed and is operational. I also acknowledge that the above technicians have been trained to my satisfaction in those areas of safety and operation as indicated above.

Management Name (print): _____

Date: _____

Management Signature: _____

THIS PAGE INTENTIONALLY LEFT BLANK

1. Getting Started

1.1 Introduction

This manual provides operation instructions and information required to operate the Road Force® Elite GSP9700 Balancer. Read and become familiar with the contents of this manual prior to operating the Road Force® Elite GSP9700 Balancer.

The owner of the Road Force® Elite GSP9700 Balancer is solely responsible for arranging technical training. The Road Force® Elite GSP9700 Balancer is to be operated only by qualified trained technicians. Maintaining records of personnel trained is solely the responsibility of the owner and management.

This manual assumes the technician has already been trained in basic balancing procedures.

Corporate Information

Hunter Engineering Company
11250 Hunter Drive
Bridgeton, MO 63044 U.S.A.

Phone: 314-731-3020 / Fax: 314-731-1776
Web: www.hunter.com

References

This manual assumes that you are already familiar with the basics of tire balancing. The first section provides the basic information needed to operate the The Road Force® Elite GSP9700. The following sections contain detailed information about equipment operation and procedures. “Italics” are used to refer to specific parts of this manual that provide additional information or explanation. For example, “*1.3 Road Force® Elite GSP9700 Main Screen Components*” on page 14. These references should be read for additional information to the instructions being presented.

1.2 For Your Safety

Hazard Definitions

Watch for these symbols:



CAUTION: Hazards or unsafe practices, which could result in minor personal injury or product or property damage.



WARNING: Hazards or unsafe practices, which could result in severe personal injury or death.



DANGER: Immediate hazards, which will result in severe personal injury or death.

These symbols identify situations that could be detrimental to your safety and/or cause equipment damage.

IMPORTANT SAFETY INSTRUCTIONS

Read all instructions before operating the Road Force® Elite GSP9700 Balancer. Read and follow the instructions and warnings provided in the service, operation and specification documents of the products with which this Road Force® Elite GSP9700 Balancer is used (i.e., automobile manufacturers, tire manufacturers etc.).

Do not operate equipment with a damaged cord or equipment that has been dropped or damaged until a Hunter Service Representative has examined it.

Always unplug equipment from electrical outlet when not in use. Never use the cord to pull the plug from the outlet. Grasp plug and pull to disconnect.

If an extension cord is necessary, a cord with a current rating equal to or more than that of the equipment should be used. Cords rated for less current than the equipment may overheat. Care should be taken to arrange the cord so that it will not be tripped over or pulled.

Verify that the electrical supply circuit and the receptacle are properly grounded.

To reduce the risk of electrical shock, do not use on wet surfaces or expose to rain.

Verify the appropriate electrical supply circuit is the same voltage and amperage ratings as marked on the balancer before operating.



DO NOT ALTER THE ELECTRICAL PLUG. Plugging the electrical plug into an unsuitable supply circuit will damage the equipment and may result in personal injury.

To reduce the risk of fire, do not operate equipment near open containers of flammable liquids (gasoline).

Read and follow all caution and warning labels affixed to your equipment and tools. Misuse of this equipment can cause personal injury and shorten the life of the balancer.

Keep all instructions permanently with the unit.

Keep all decals, labels, and notices clean and visible.

To prevent accidents and/or damage to the balancer, use only Hunter Road Force® Elite GSP9700 Balancer recommended accessories.

Use equipment only as described in this manual.

Never stand on the balancer.

Wear non-slip safety footwear when operating the balancer.

Keep hair, loose clothing, neckties, jewelry, fingers, and all parts of body away from all moving parts.

Do not place any tools, weights, or other objects on the safety hood while operating the balancer.

ALWAYS WEAR OSHA APPROVED SAFETY GLASSES. Eyeglasses that have only impact resistant lenses are NOT safety glasses.

Keep the safety hood and its safety interlock system in good working order.

Verify that the wheel is mounted properly and that the wing nut is firmly tightened before spinning the wheel.

The safety hood must be closed before touching the green "START" button, to spin the wheel.

Hood Autostart will cause the balancer shaft to spin automatically upon hood closure. For the next Autostart, the safety hood has to be lifted to the full up position and then closed.

Raise safety hood only after wheel has come to a complete stop. If safety hood is raised before the spin is completed, the weight values will not be displayed.

Do not let cord hang over any edge or contact fan blades or hot manifolds.

The red "STOP" button, can be used for emergency stops.

 **Never reach under the hood while the balancer is performing a runout measurement or balance spin.**

SAVE THESE INSTRUCTIONS

Electrical

The Hunter Road Force® Elite GSP9700 Balancer is manufactured to operate at a specific voltage and amperage rating.

Make sure that the appropriate electrical supply circuit is of the same voltage and amperage ratings as marked on the balancer.

 **DO NOT ALTER THE ELECTRICAL PLUG.** Plugging the electrical plug into an unsuitable supply circuit will damage the equipment.

Make sure that the electrical supply circuit and the appropriate receptacle is installed with proper grounding.

To prevent the possibility of electrical shock injury or damage to the equipment when servicing the balancer, power must be disconnected by removing the power cord from the electrical power outlet.

After servicing, be sure the balancer ON/OFF switch is in the "O" (off) position before plugging the power cord into the electrical power outlet.

This device is rated as Class A for radiated emissions.

In the event of radio interference, the display read out may flicker - this is normal.

Decal Information and Placement

Right Side View

(Figure 1.)

Decal **128-1244-2** cautions the operator that spindle rotation may occur with foot pedal depression and to keep clear of clamping components during Quick-Thread® shaft rotation.

Decal **128-964-2** gives the maximum wheel diameter and maximum wheel weight for the Road Force® Elite GSP9700.

EN/IEC Class 1 Laser Product Certification is shown on Decal **128-1638-2**. This labels shows the EN/IEC standards for a Class 1 Laser Product.

An explanation of FDA compliance standards is shown on Decal **128-1117-2**. FDA performance standards compliance is shown on the decal.

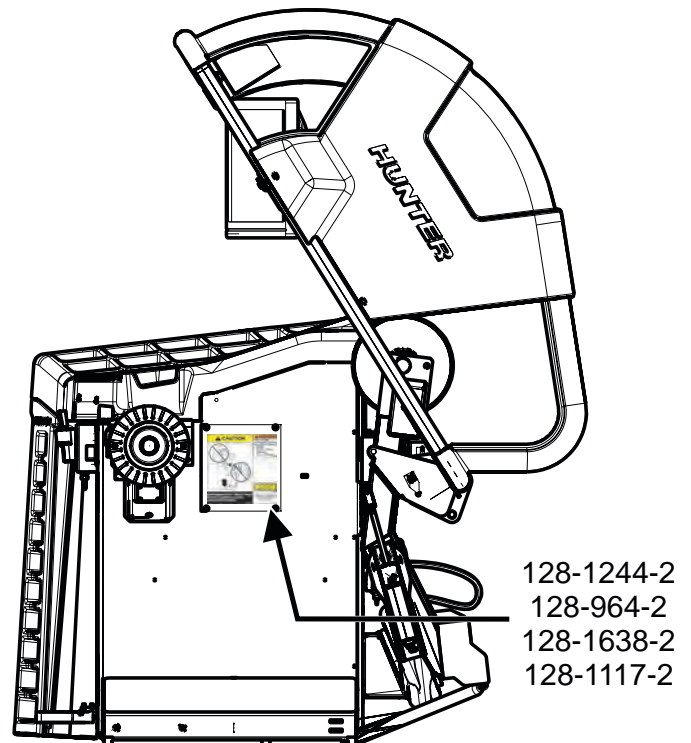

Figure 1.



Figure 2.

Front View

(Figure 3.)

FDA standards for Class 2M laser compliance are shown on Decal 128-1155-2 (for TDC Units).

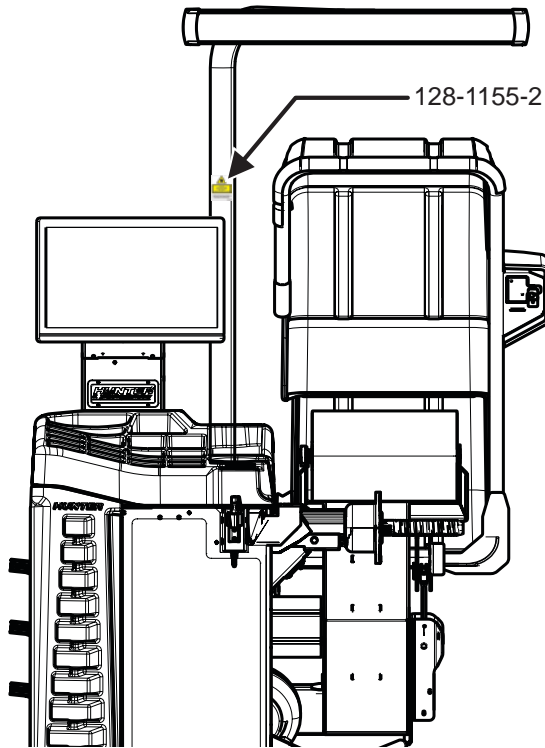

Figure 3.

The Class 2M laser apertures are located at either end of the TDC header. (Figure 4.)



Figure 4.

Left Side View

(Figure 5.)

Decal 128-391-2-00 cautions that the unit may automatically start upon closing of the hood when Hood Autostart is enabled.

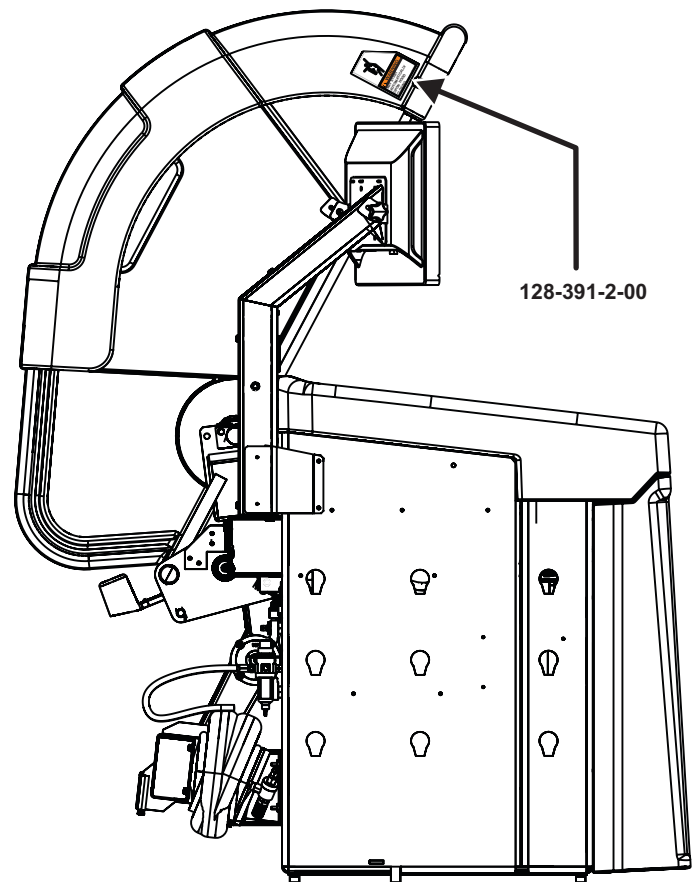

Figure 5.

Back View

(Figure 6.)

Decal 128-381-2 warns the operator not to remove the cover of the Road Force Elite / GSP9700 because of the risk of electrical shock and not to use below garage floor level.

ETL certification standards are outlined on Decal 128-1120-2. Additionally, users are cautioned not to use the balancer below garage floor level.

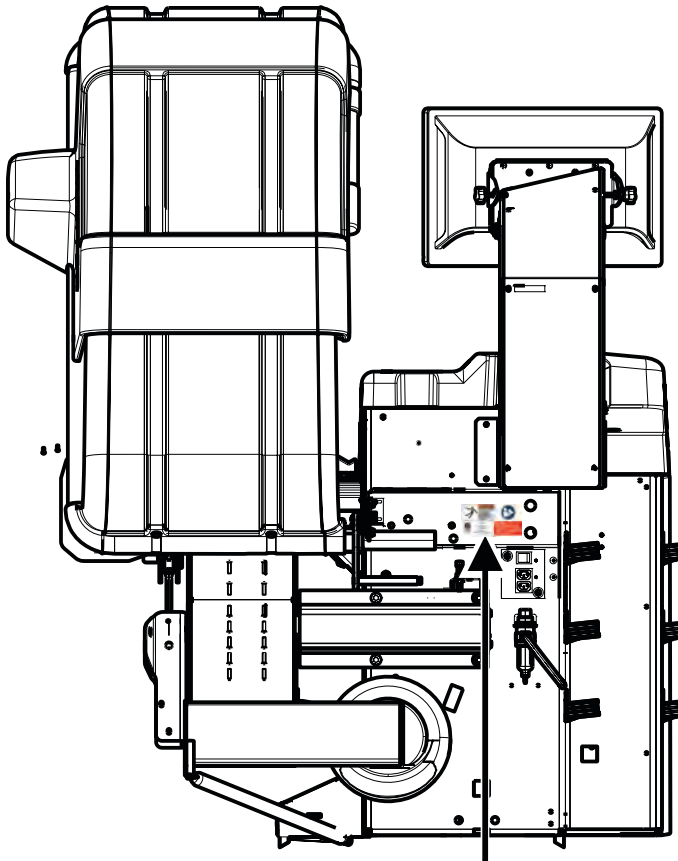

128-381-2
128-1120-2

Figure 6.

A manufacturer's identification label is also on the rear of the balancer. (Figure 7.)



Figure 7.

Specific Precautions/Power Source

The Road Force® Elite GSP9700 Balancer is intended to operate from a power source that will apply 230VAC +10% / -15%, 1 phase, 10 amp 50/60 Hz, power cable includes NEMA 20 amp plug, L6-20P, between the supply conductors of the power cord. The power cord supplied utilizes a twist lock connector, NEMA L6-20P. (Figure 8.) This machine must be connected to a 20 amp branch circuit. Please refer all power source issues to a certified electrician. Refer to "Installation Instructions for Road Force® Elite GSP9700 Balancer," Form 7112-T.



Figure 8.



A protective ground connection, through the grounding conductor in the power cord, is essential for safe operation. Use only a power cord that is in good condition.



For information on converting from single phase NEMA L6-20P plug to three phase NEMA L15-20P plug refer to Form 5350-T, "NEMA L6-20P to NEMA L15-20P Power Plug Conversion Instructions."

Specific Precautions/Optical Scan Laser

The Optical Scan Laser is a class 1 laser designed to measure the profile of wheel assemblies. The laser is not a field serviceable part. No maintenance is to be performed on the laser. (Figure 9.)



Figure 9.

Wavelength: 650nm.

Specific Precautions/HammerHead® TDC Laser Indicator (Optional)

The TDC (Top Dead Center) Laser Indicator is a class 2M laser designed to aid in applying clip-on weights. The laser is not a field serviceable or adjustable part.

Use caution in regard to reflective materials around the laser and never look into the laser beam.

LASER RADIATION - DO NOT STARE INTO THE BEAM OR VIEW DIRECTLY WITH OPTICAL INSTRUMENTS.

Viewing the laser output with magnifiers or related optical instruments within a distance of 100mm from the laser aperture may pose an eye hazard. (Figure 10.)

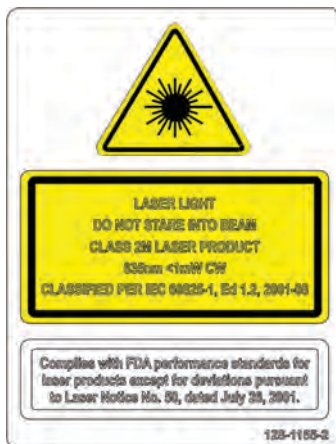

Figure 10.

Turning Power ON/OFF

Push Button Switch

The Road Force® Elite GSP9700 is equipped with a push button power switch located on the left side of the LCD support. Use this switch for normal shut down and restarting procedures. (Figure 11.)



Figure 11.

Main Power Switch



To prevent loss of data, always use the push button switch on the LCD support to power the balancer on and off. Then use the main power switch to remove power to the entire unit.

The main power ON/OFF switch is located on the back of the balancer cabinet. To power the balancer "ON," press the "I" side of the ON/OFF switch. To turn all power the balancer "OFF," press the "O" side of the ON/OFF switch. (Figure 12.)

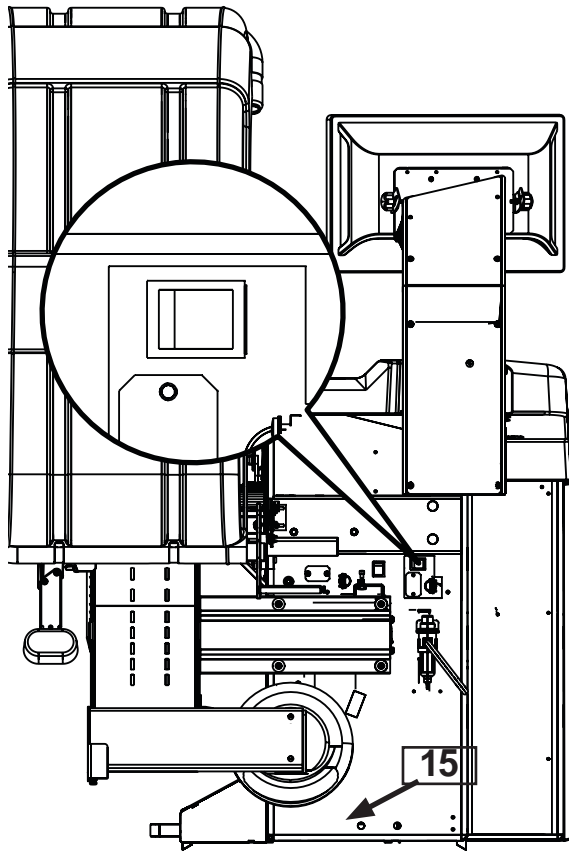

Figure 12.

After the Road Force® Elite GSP9700 Balancer performs a self-check, the main balance screen will appear indicating the unit is ready for use. (Figure 13.)



Figure 13.

Equipment Installation and Service

Only a Hunter Factory-Authorized Representative should perform installation.

This equipment contains no operator serviceable parts. All maintenance and repairs must be referred to a qualified Hunter Service Representative.

Equipment Specifications

Electrical	
Voltage:	230VAC +10% / -15%, 1 phase, 50/60 Hz, power cable includes NEMA 20 amp plug, L6-20P
Amperage:	10 amperes
Wattage:	3450 watts (peak)
Air	
Air Pressure Requirements:	100-175 PSI (6.9-12.0 bar)
Approximate Air Consumption:	4 CFM (110 Liters/Minute)
Atmospherics	
Temperature:	+32°F to +122°F (0°C to +50°C)
Relative Humidity:	Up to 95% Non-condensing
Altitude:	Up to 10000 ft. (3048 m)
Sound Pressure Level	
Equivalent continuous A-weighted sound pressure at operator's position does not exceed 70 dB (A).	

Explanation of Symbols

These symbols may appear on the equipment.

	Alternating current.
	Earth ground terminal.
	Protective conductor terminal.
	ON (supply) condition.
	OFF (supply) condition.
	Risk of electrical shock.
	Stand-by switch.
	Not intended for connection to public telecommunications network.

1.3 Road Force® Elite Main Screen Components

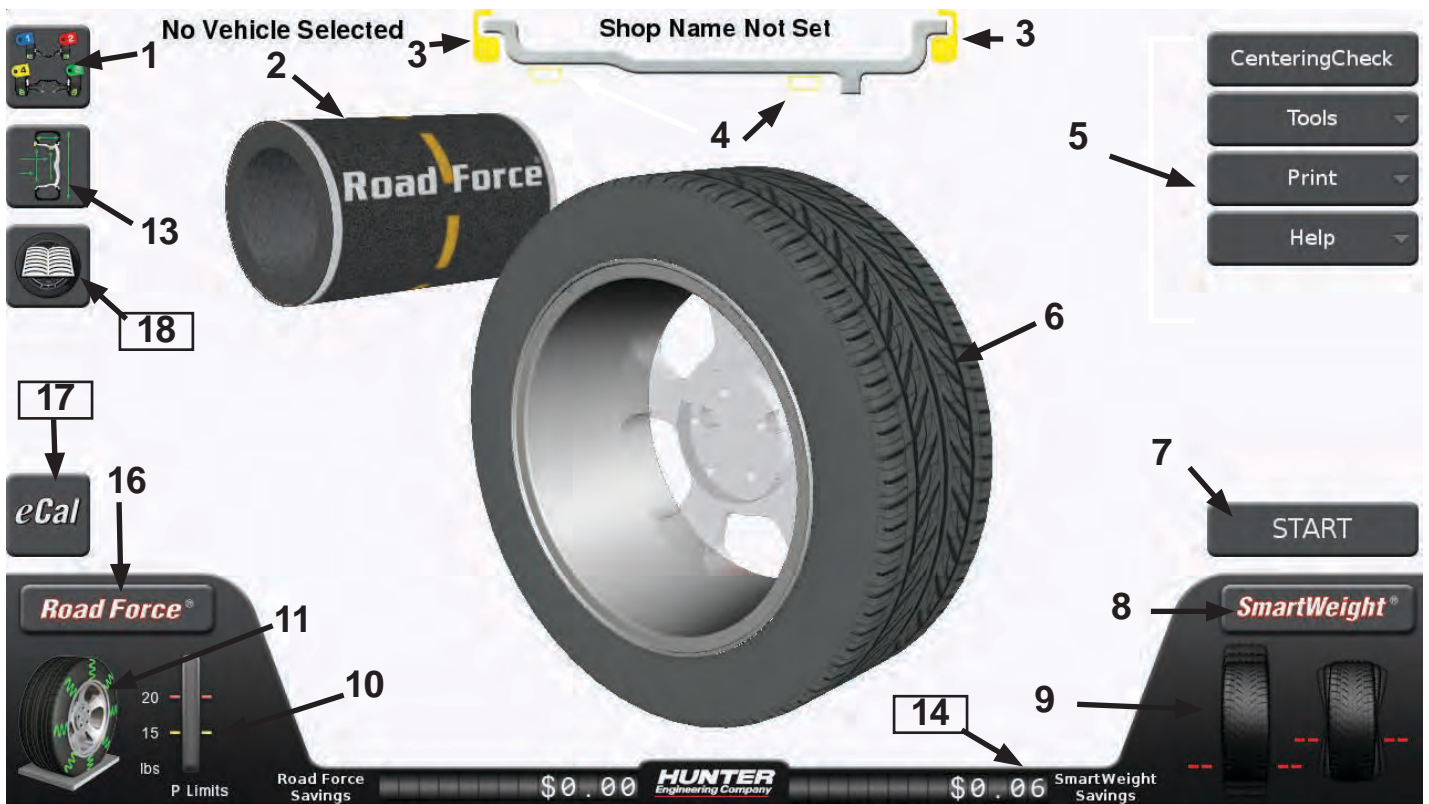

1. Tire Stack / Vehicle Plan View Tab	9. Imbalance and Couple Force Display
2. Load Roller	10. Road Force Limits Display
3. Clip Weight Plane	11. Road Force Wheel Assembly Display
4. Tape Weight Plane	12. Road Force Menu Button
5. Context Sensitive Menu	13. Wheel Dimensions Tab
6. Wheel Assembly Display	14. SmartWeight® Savings Odometer
7. Start / Stop / Servo Button	15. Road Force Savings Odometer
8. SmartWeight® Menu Button	16. Road Force® Menu Button
17. eCal button	18. Vehicle Selection

1.4 Road Force® Elite Components

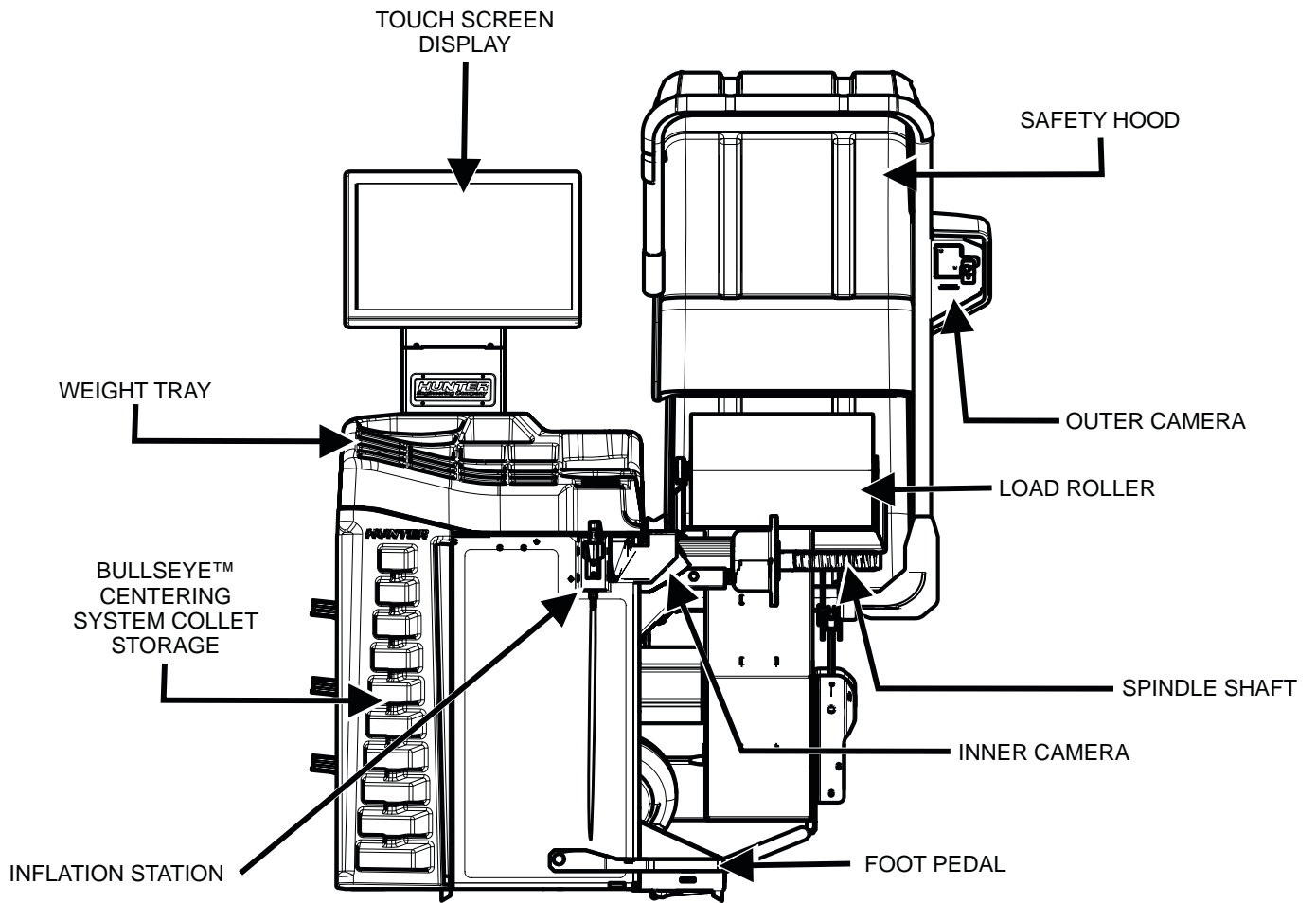

Figure 14.

1.5 Operating the Balancer

Main Balance Screen

Pull-out tabs are on the left for Tire Stack/Vehicle Information (upper tab) and Wheel Dimensions (lower tab). Buttons along the right side allow navigation to other screens and activities. Buttons in the lower left and right portions of the screen allow navigation to Road Force® and SmartWeight® procedures and options. (Figure 15.)



Figure 15.

Main Balance Screen - Error Pop-ups

If the operator attempts to perform an illegal operation in the main balance screen, an error pop-up with appropriate information will be displayed. For example, the above screen is displayed if operator attempts to start a spin without first lowering the hood. (Figure 16.)



Figure 16.

Main Balance Screen - Tire Rash

After a Road Force® spin (or StraightTrak®), a colored road rash will appear on the tire. This signifies the measured Road Force® of the assembly, and corresponds to the value and color presented in the Road Force® animation in the lower left portion of the screen. (Figure 17.)



Figure 17.

Main Balance Screen - Prompt Text

When the operator needs more info in a non-error condition, prompting text will appear in the lower portion of the screen. (Figure 18.)



Figure 18.

Main Balance Screen – Enable and Disable Load Roller

To enable or disable the load roller in the main balance screen, touch the load roller on the screen to cycle through all available options. (Figure 19.)



Figure 19.

Main Balance Screen – Inflation Station

When the operator attempts a loaded balance spin, and if “Prompted Inflation Station” is enabled in Setup, the operator will be prompted to answer if the tire has been inflated to the manufacturer’s specification. (Figure 20.)



Figure 20.

If the answer is “No”, the operator will be prompted to inflate the tire. (Figure 21.)



Figure 21.

If the answer is “Yes”, then the spin will proceed.

Main Balance Screen – Performing a Spin

During a loaded balance spin, several things occur on the screen. First, the green Start button is replaced with a red Stop button and the tire assembly spins in 3D space. (Figure 22.)



Figure 22.

As soon as the balance portion of the spin is complete, weights will appear on the screen. (Figure 23.)



Figure 23.

During each portion of the loaded spin, the text in the lower portion of the screen will alert the operator about what is being measured. (Figure 24.), (Figure 25.) and (Figure 26.)



Figure 24.



Figure 25.



Figure 26.

If StraightTrak® is enabled, the lateral measurement will begin after Road Force® has been measured. (Figure 27.) and (Figure 28.)



Figure 27.



Figure 28.

After the loaded spin is complete, and if dimensions have been entered, the 3D scene will show all information necessary to balance the assembly including; Assembly Force, Weight Amounts, Weight Type, and Weight Position. (Figure 29.)



Figure 29.

Main Balance Screen – Servoing To Position

If servoing is enabled in Setup, the balancer will servo either the inner or outer place weight position to top-dead-center. To servo to the next position, the operator can either touch the “Servo” button or touch the corresponding weight amount. (Figure 30.)



Figure 30.

Main Balance Screen – Road Force® Buttons

Touching the Road Force® button expands a set of button options. The load roller can be disabled/enabled. The operator can change the Road Force® limits. The “Show Savings” button can show detailed views of the cost savings from Road Force® balancing. And finally, the operator can select one of three Road Force® procedures: ForceMatching®, Measuring Individual Lateral Force, and 180 Matching. Display of historical data is also available. (Figure 31.)



Figure 31.

Main Balance Screen – SmartWeight® Buttons

Touching the SmartWeight® button expands a set of button options. SmartWeight® can be disabled or enabled, Performance Mode can be disabled or enabled and Weight savings can be viewed. (Figure 32.)



Figure 32.

Secondary Screens - Print Screen Button

Any secondary screens used to perform balancing procedures or to view graphs will have a print button which will send a copy of the current screen to the printer. The background will turn white to help conserve ink.



Figure 33.

THIS PAGE INTENTIONALLY LEFT BLANK

2. Introduction to Balancing

2.1 Balance Forces

Balancing Theory - Static Imbalance

As the word static implies, the tire will be balanced when at rest. For example, if an unmoving assembly was centered on a cone and was balanced, it would be statically balanced. A “bubble balancer” is designed to statically balance a tire/wheel assembly. (Figure 34.) and (Figure 35.)

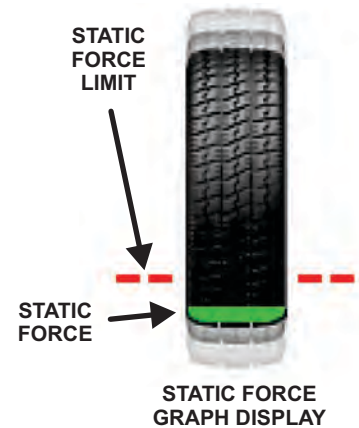

Figure 34.

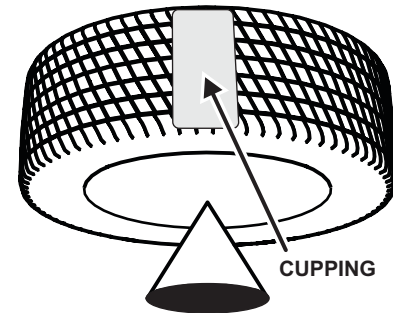
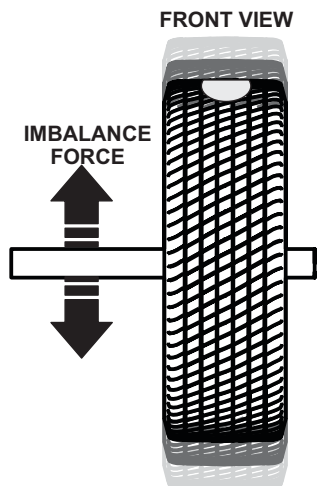

Figure 35.

Static imbalance is a condition where one amount of weight located in the center of the tire/wheel assembly causing an imbalance. As the weight rotates, centrifugal forces are created causing the wheel to lift as the weight reaches top dead center. This lifting motion causes the tire/wheel assembly to move “up and down” creating a bounce that can be felt. This static imbalance condition is evident by a “jiggle” or up-down movement of the steering wheel. These vibrations may also be apparent in the body, with or without steering wheel shake.

A statically imbalanced tire driven for an extended period may cause “cupping” in the tire’s tread, create vibration, and adversely effect handling. (Figure 36.)



STATIC IMBALANCE
Figure 36.

Static balancing alone is a seldom-recommended procedure. For example, a single weight is commonly placed on the inner clip weight position for cosmetic purposes. This is not a recommended practice and usually insures the assembly is not properly dynamically balanced. The assembly may then experience side-to-side imbalance while in motion, causing a shimmy condition and objectionable vibration. (Figure 37.)

NON-RECOMMENDED FORM OF
STATIC BALANCING



BALANCE WEIGHT IS NOT IN
CENTER OF WHEEL
Figure 37.

Balancing Theory - Couple Imbalance

Dynamic imbalance is defined as a condition where one or more locations of the tire/wheel assembly are heavier causing an imbalance force and/or an imbalance shake and wobble. Shown below is a tire/wheel assembly with two heavy spots of equal weight which are located 180 degrees from each other on opposite sides. As this assembly rotates, centrifugal forces cause a large imbalance wobble to be created, but the imbalance force (as well as the static imbalance) will be zero. A wheel with this condition will cause a wobble or shimmy to be

felt in the steering wheel. Excessive dynamic imbalance of this type creates a shimmy that transfers through the suspension components to the occupants of the vehicle, especially at higher speeds. (Figure 38.) and (Figure 39.)

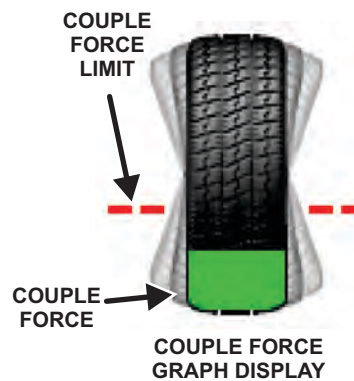

Figure 38.

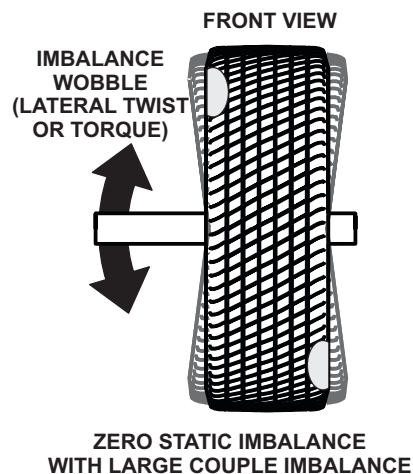

Figure 39.

Modern “dynamic” balancers spin the wheel in order to measure both the up and down static imbalance force and couple wobble or shimmy related imbalance (side-to-side).

Dynamic balancers direct the operator to place correction weights on the inside and outside correction locations of the rim, or a single weight away from the center of the wheel, so that both imbalance shake (static) and imbalance wobble (couple) will be eliminated. (Figure 40.)

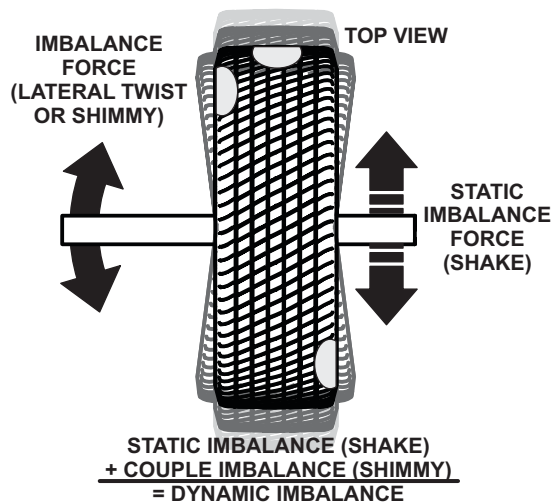

Figure 40.

2.2 SmartWeight® Balancing Technology

SmartWeight® Balancing Technology is not a procedure. Rather, it is a technology that measures the forces of couple side-to-side shimmy and static up-and-down shake and computes the correction weight required to reduce these forces. This reduces the amount of weight used, reduces time, reduces check spins, “chasing weights”, and saves shop time and money.

SmartWeight® Balancing Technology can reduce the number of steps in the balancing process. Not only does SmartWeight® Balancing Technology give the customer a better riding vehicle, it also helps the environment by using less corrective weight.

Static and non-rounding modes are eliminated to simplify operation. Always enter at least two weight positions during wheel measurement in SmartWeight® balancing mode. All other functions are identical to the traditional balancing method.

Static and Dynamic Imbalance Sensitivity

As a general rule of thumb, to achieve the best balance on an average sized tire and wheel assembly Residual static imbalance should be less than 1/4 ounce (7 grams).

Residual couple imbalance should be less than 3/4 ounce (21 grams).

- Residual couple imbalance is preferred over remaining static imbalance.
- It takes much more residual couple imbalance weight to cause a vibration than the same amount of static imbalance correction weight.
- The larger the diameter used for weight placement, the smaller the amount of correction weight is required for static correction.
- The wider the distance between the two weight placement locations, the smaller the amount of correction weight is required for couple correction.
- If static balance is the only option, always verify that the remaining couple residual imbalance is within acceptable tolerance. This can only be verified using SmartWeight® balancing.



SmartWeight® balancing performs this check automatically.

2.3 SmartWeight® Balancing Technology Dynamic Weight Planes

SmartWeight® requires the operator to enter at least two weight planes. This balancing method will automatically determine if one or both weight planes require a weight to be added. This eliminates “blinded” static single plane balancing, which alone may not be sufficient to solve couple vibration issues.

The Road Force® Elite GSP9700 balancer offers two primary ways to balance tires:

1. SmartWeight® Balancing Technology (Figure 41.)



Figure 41.

2. Traditional balancing technology (Figure 42.)



Figure 42.

Both of these methods can balance tires dynamically. The main difference being that SmartWeight® will reduce the amount of corrective weight in a basic wheel balancing situation and automatically optimize static force reduction and single plane weight placement.

2.4 Using SmartWeight® Balancing Technology

The SmartWeight® balancing forces display varies greatly from the standard balancing display. SmartWeight® tire graphs independently display the static and couple forces within a tire/wheel assembly. A single plane (static) mode and non-round off modes are no longer necessary. The traditional “static” and “dynamic” modes are eliminated. The traditional non-round off mode is eliminated. These modes are no longer necessary with SmartWeight® balancing. (Figure 43.)

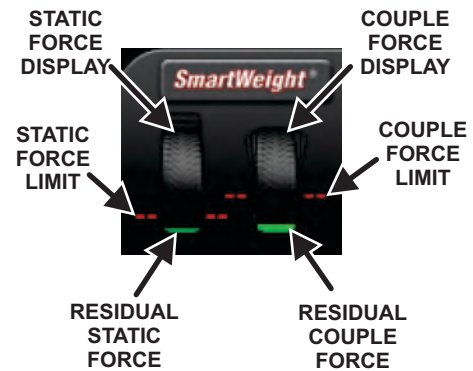

Figure 43.

The red-dotted line represents the acceptable amount of force the tire and wheel assembly can have that will not result in a ride problem. Any forces below that line will be shown in green. Any forces that are above that level will be shown in red and indicate an excessive amount of force.

Install a tire/wheel assembly as normal. Rim measurements are not required to determine if the balance forces are exceeded. Lower the hood and spin. (Figure 44.)



Figure 44.

Prior to balance spin, the tire graphs will display no color. The SmartWeight® balance force graphs will display red for excessive forces and green for acceptable amounts of force. (Figure 45.)



Figure 45.

If the SmartWeight® balancing procedure requires correction weights, wheel dimensions will be required. Close the hood and perform a spin.

After the spin is complete, the screen will display the amount and location of corrective weight necessary. (Figure 46.)



Figure 46.

Install the weights as indicated on the screen using the TruWeight™ feature. Lower the hood to re-spin and check the balance.

The balancer displays “OK,” indicating that the force levels are reduced to within the acceptable tolerances.



Figure 47.

Switching from SmartWeight® Balancing Technology to Traditional Dynamic Balancing

At any time, SmartWeight® Balancing Technology can be switched to standard balancing provided that both standard and SmartWeight® balancing modes are enabled in setup.

Touch the SmartWeight® button to display the SmartWeight® menu buttons.



SmartWeight® Balancing Technology is the default balancing method and is the most recommended way to accurately balance wheel / tire assemblies.

Touch the Disable SmartWeight® button.

The balancer is now in traditional dynamic balancing mode. .)



When changing to traditional dynamic balancing mode, weight amounts as well as weight placement locations change. (Figure 48.) and (Figure 49.)



Figure 48.



Figure 49.

Switching from Traditional Dynamic Balancing to Traditional Static Balancing.

In non-SmartWeight® mode, the balancer can be switched from dynamic balancing to static balancing.

Dynamic mode is selected: (Figure 50.)



Figure 50.

Touching the static mode icon will switch to static mode. (Figure 51.)



Figure 51.

Blinding and Rounding

In non-SmartWeight® mode, the balancer can display either an “actual” or “blinded and rounded” amount of imbalance.

Touching the magnifying glass icon next to the dynamic or static icons will toggle blinding and rounding on or off.

Dynamic mode, blinding/rounding is disabled: (Figure 52.)



Figure 52.

Static mode, blinding/rounding is enabled: (Figure 53.)



Figure 53.

Enable Performance Mode

In SmartWeight® mode, the balancer can be switched to performance mode.

Touch the Enable Performance Mode button.

Show Savings

Touch the Show Savings button.

The SmartWeight® Savings screen will be displayed. (Figure 54.)

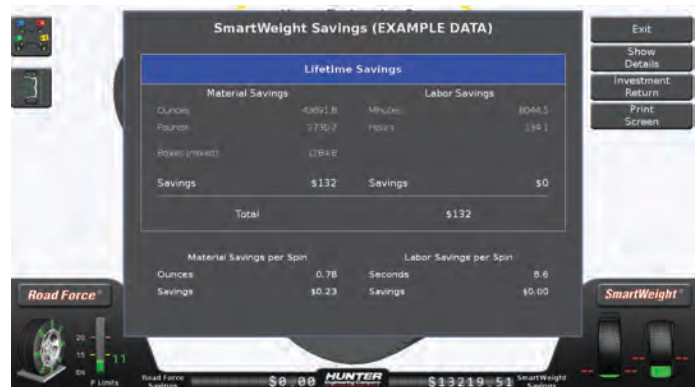

Figure 54.

Touch the Show Details button to view details of SmartWeight® savings.

The Weight Savings screen will be displayed. (Figure 55.)

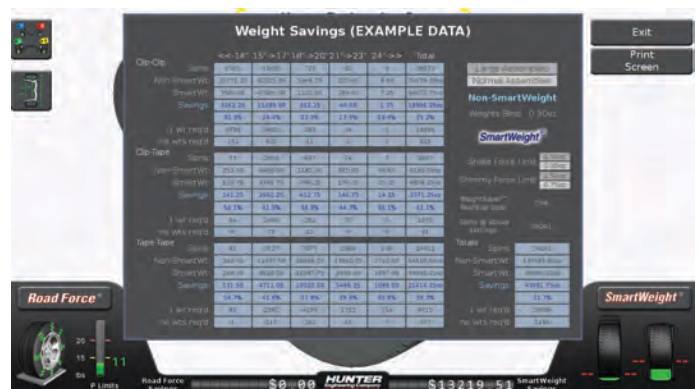

Figure 55.

Touch the Investment Return button.

The SmartWeight® and Road Force® Investment Return screen will be displayed. (Figure 56.)



Figure 56.

Road Force® Savings

Savings generated through prevented comebacks using the Road Force® roller can also be viewed.

Touch the Road Force® button.

In the Road Force® menu, touch the Show Savings button.

The Road Force® savings screen will be displayed. (Figure 57.)



Figure 57.



THIS PAGE INTENTIONALLY LEFT BLANK



3. Balancing Procedures

3.1 Mounting a Wheel Using Wheel Lift (Optional)

The wheel lift is an optional feature on the Road Force® Elite GSP9700 series balancer.

Raising the Wheel Assembly

Slide the appropriate Bullseye™ Centering System collet onto the spindle shaft. Position wheel lift carriage at the end of the wheel lift rail. (Figure 67.)

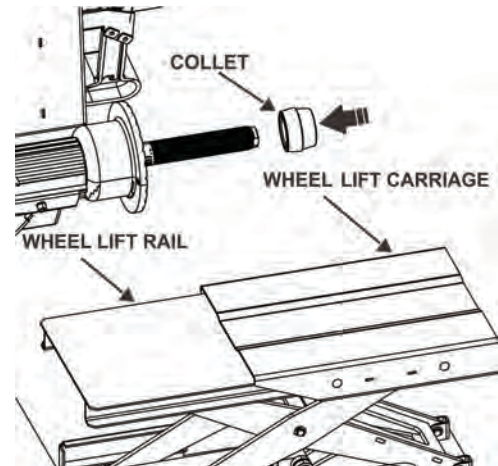

Figure 58.

Press the lift control handle “down” until the trolley carriage is at its lowest level. (Figure 68.)

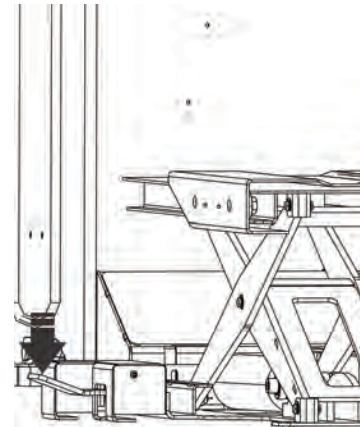

Figure 59.

Roll the wheel assembly onto the wheel lift carriage. (Figure 69.)

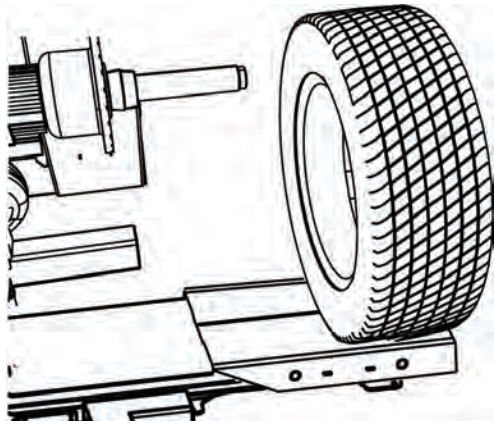

Figure 60.

Raise the lift control handle “up” to move the lifting assembly into a position where the wheel assembly can be installed onto the spindle shaft. (Figure 70.)

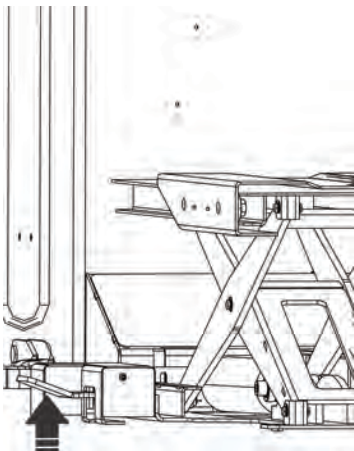

Figure 61.

Slide the tire/wheel assembly onto the spindle and center on the collet. Verify that the wheel assembly is centered vertically on the spindle shaft. (Figure 71.)

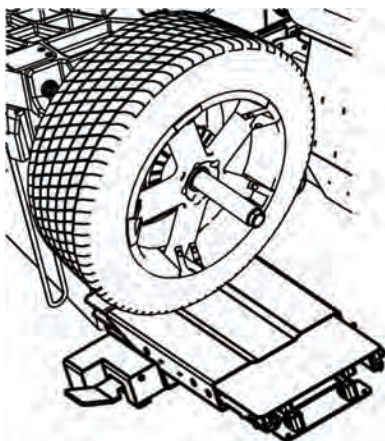

Figure 62.

i Lower wheel lift as needed to clamp wheel, but keep the wheel lift carriage in place under the wheel assembly.

Clamp wheel onto the spindle shaft.

Keep the wheel lift carriage in place under the wheel assembly and close the hood. The lifting assembly will automatically lower and park the carriage below. (Figure 72.) and (Figure 73.)

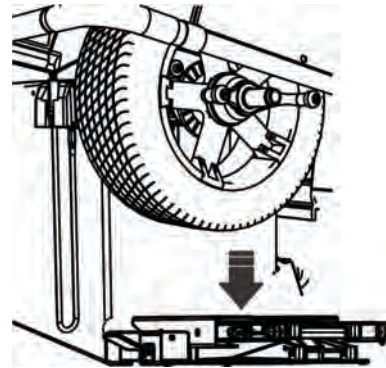

Figure 63.

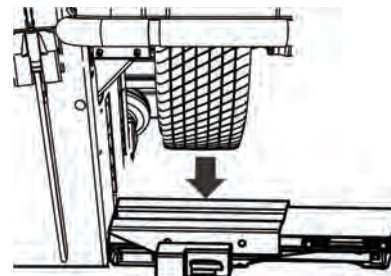

Figure 64.

i Allowing the balancer to park the wheel lift carriage in place under the wheel assembly will make the removal and lowering of wheel assembly easier and quicker.

Lowering the Wheel Assembly

Starting with the wheel lift carriage parked under the wheel assembly; raise the lift control foot pedal “up” to move the lifting assembly to the wheel assembly. Release the lift control foot pedal when the assemblies contact one another. (Figure 7.)

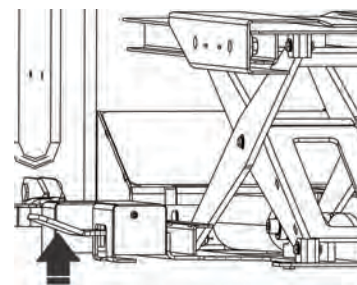

Figure 65.

Remove wheel clamp.

Starting with the wheel lift carriage parked under the wheel assembly; raise the lift control handle “up” to move the lifting assembly to the wheel assembly.

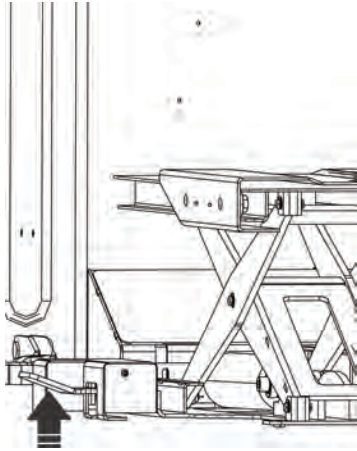

Figure 66.

Slide the carriage with wheel assembly to the end of the wheel lift rail.

Press the lift control handle “down” until the carriage is at its lowest level.

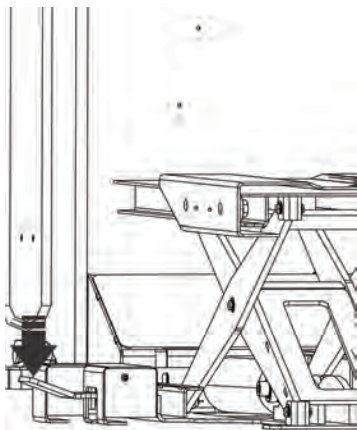

Figure 67.

Roll wheel assembly from carriage.

3.2 Mounting the Wheel on the Balancer Spindle Shaft



Use only cones, collets and accessories that are specifically designed for the Road Force® Elite GSP9700.

Since today's vehicle designs are lighter and more sensitive to road feel, it is critical to achieve the best balance. Proper balance requires that the tire/wheel assembly be centered on the balancer. Tire/wheel assemblies can be balanced to zero, even with the tire/wheel assembly mounted off-center. The main objective of the balancer operator is to center the wheel on the hub and shaft, using the best available method. Mounting the wheel off-center creates incorrect measurements of imbalance and runout conditions.

Remove any existing wheel weights, rocks and debris from the tire tread. Clean the center hole of the wheel. Inspect inside of wheel for excessive accumulation of dirt and debris. Remove if necessary before balancing.

Accurate balancing depends on accurately centering the wheel. Choose the proper Bullseye™ Centering System collet by placing it in the center hole of the wheel to be balanced.



If basic collets and adaptors do not fit the wheel, additional centering adaptors will be necessary. A wheel that cannot be properly centered cannot be properly balanced. All balancers require additional centering adaptors to properly center certain types of wheels. For additional information, refer to “Wheel Balancer Accessories”, Form 3203-T for optional accessories.

Installing the Wheel - Typical Scenario

With the safety hood open, place the collet on the spindle shaft against the captivated spring. (Figure 76.)

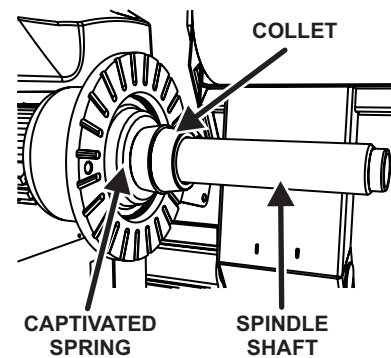

Figure 68.

Position the wheel with the inside surface facing the balancer, centered on the collet. (Figure 77.)

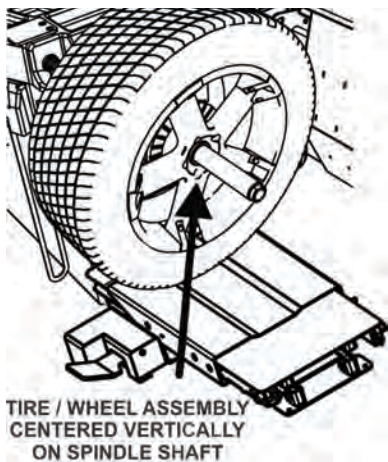

Figure 69.

Install the plastic clamping cup and wing nut on the spindle shaft against the wheel and secure the entire assembly by firmly tightening the wing nut. (Figure 78.)

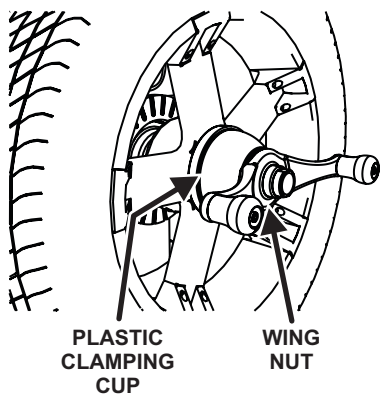

Figure 70.

Depress and hold down the Spindle-Lok® foot pedal while tightening the wing nut. Holding the shaft locked while tightening the wing nut improves centering accuracy. (Figure 79.)

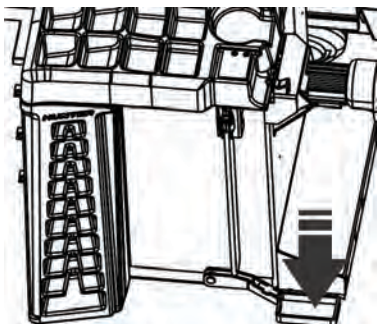

Figure 71.

Slowly roll the wheel towards you while tightening the wing nut. This improves accurate wheel centering, since the wheel is allowed to roll up the taper of the collet as opposed to forcing it to slide up the collet. (Figure 80.)

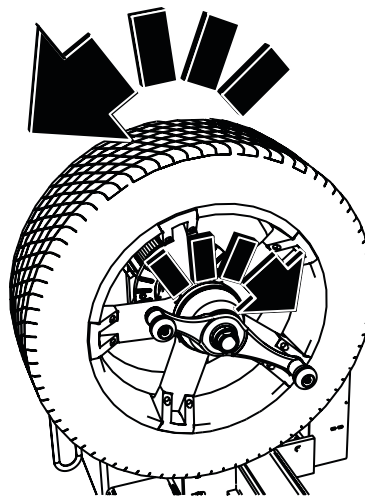

Figure 72.

Installing the Wheel Using Quick-Thread® Wheel Clamping



Keep clear of clamping components during Quick-Thread® shaft rotation.

With the safety hood open, place the collet on the spindle shaft against the captivated spring. (Figure 81.)

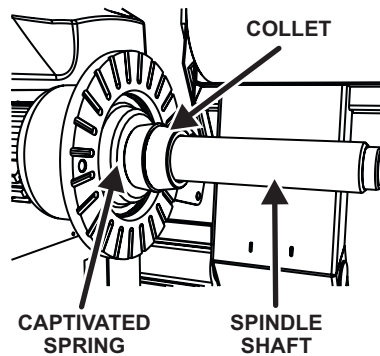

Figure 73.

Lift the wheel assembly onto the shaft as normal without threading on the wing nut. (Figure 82.)

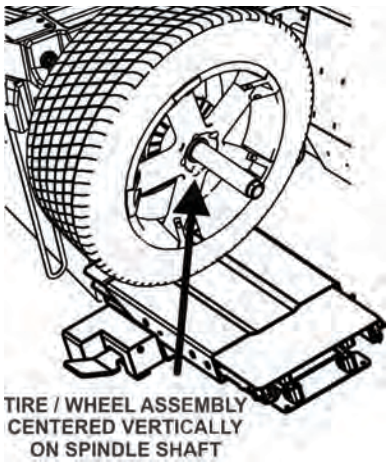

Figure 74.

With the left hand, hold the rim over the collet to remove the weight of the rim from the spindle shaft and to allow maximum quick-thread wing nut travel.

Place the wing nut on the spindle and rotate one full turn onto the spindle threads. (Figure 83.)

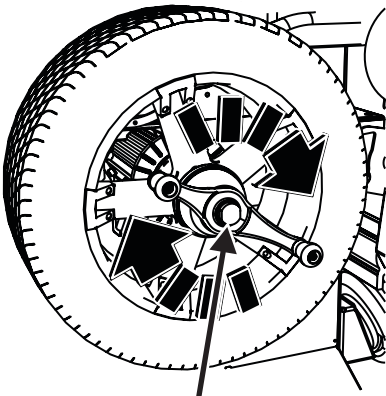

Figure 75.

With the right hand, hold one handle of the wing nut while lifting the rim. (Figure 84.)

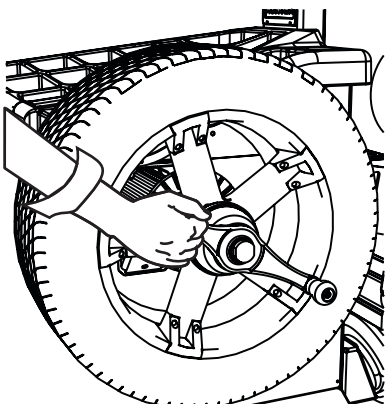

Figure 76.

i Heavier wheel assemblies may require extra lifting to prevent the software-limited motor torque control from stopping the rotation of the spindle.

Tap the foot pedal twice and the spindle will rotate to install the wing nut to save threading time.

A single tap within the first three seconds of rotation will reverse the direction of rotation. A single tap after the first three seconds of rotation will stop rotation.

Quick-Thread® spindle rotation will stop when the clamping components contact the wheel, or when the foot brake is applied for more than half of a second.

! Quick-Thread® does not tighten the wing nut! In Quick-Thread® rotation, torque allowed is minimal. Therefore, the wing nut must still be hand-tightened before balancing.

Installing the Wheel Using SpeedClamp™ Wheel Clamping (Optional)

With the safety hood open, place the collet on the spindle shaft against the captivated spring. Position the wheel with the inside surface facing the balancer, centered on the collet. (Figure 85.)

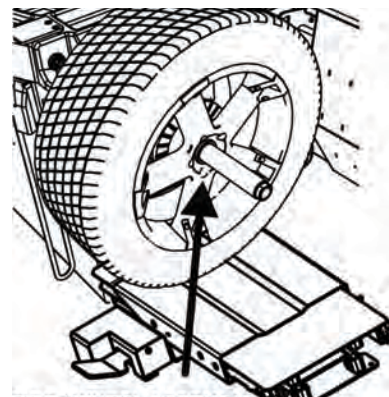

Figure 77.

Install the plastic clamping cup and SpeedClamp™ device by sliding onto the spindle shaft with the clamping cup pressed against the wheel. (Figure 86.)

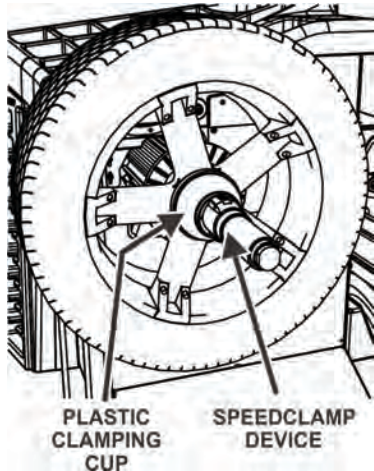

Figure 86.

Rotate the SpeedClamp™ device until it locks into place on the spindle shaft. (Figure 87.)

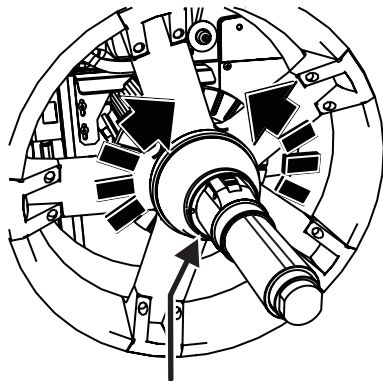

Figure 87.



Keep hands clear of clamping components during SpeedClamp™ operation.

Secure the wheel by tapping the Spindle-Lok® foot pedal twice. The SpeedClamp™ device will slide tightly against the wheel. (Figure 88.)

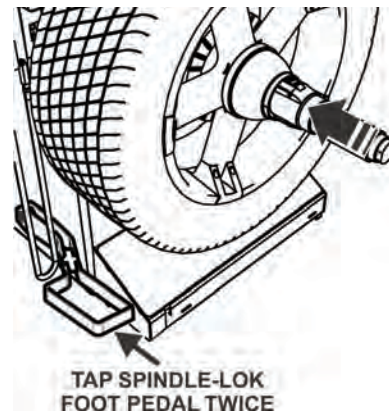

Figure 88.

To remove the SpeedClamp™ assembly, slightly tap the Spindle-Lok® foot pedal to release the pneumatically powered spindle. Squeeze the levers on the SpeedClamp™ device to disconnect the SpeedClamp™ locks from the spindle, and slide the assembly off the spindle. (Figure 89.)

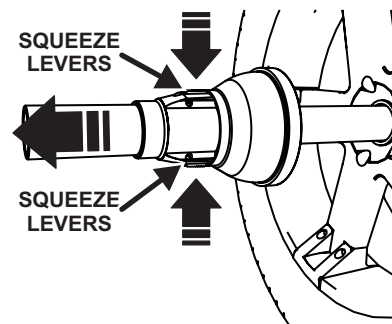

Figure 89.

3.3 CenteringCheck® Wheel Centering Feature

CenteringCheck®

CenteringCheck® is an inspection or verification of the wheel's mount to balance to identify possible centering errors, thus recognizing improper measurements.

From the main balance screen, touch the "CenteringCheck" button. (Figure 90.)



Figure 82.

CenteringCheck® Errors

If an error condition occurs during the procedure, an error popup will appear with text explaining the error.

Follow the on-screen instructions to correct the error and proceed with CenteringCheck®.

Using CenteringCheck®



CenteringCheck® provides a quick and accurate method of checking for centering errors.

CenteringCheck® may be used with either a "bare rim" or a "rim with tire assembly." On-screen prompts lead the operator through the procedure.

Mount the wheel on the spindle and securing with the wing nut / SpeedClamp™.

Lower hood and wheel will spin. (Figure 91.)



Figure 83.

When spin is complete, raise hood and rotate the wheel to position the valve stem at 12:00 o'clock. Touch the "Enter Valve Stem" button or tap the Spindle-Lok foot pedal to enter the valve stem position. (Figure 92.) and (Figure 93.)

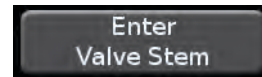



Figure 84.



Figure 85.

Hold down the Spindle-Lok® foot pedal. Loosen the wing nut / SpeedClamp™ so the wheel can be removed from the collet.



While performing this operation, the spindle shaft must stay in the same position. Use the Spindle-Lok® foot pedal to hold the shaft in place.

Loosen wing nut / SpeedClamp™ and rotate the wheel and collet approximately 180 degrees from their current positions. (Figure 94.)

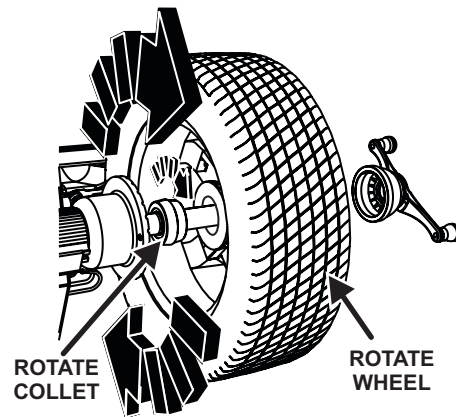

Figure 86.

Lower hood and the wheel will spin. (Figure 95.)



Figure 87.

When spin is complete, raise hood and rotate the wheel to position the valve stem at 12:00 o'clock. Touch the "Enter Valve Stem" button or tap the Spindle-Lok foot pedal to enter the valve stem position. (Figure 96.) and (Figure 97.)



Figure 88.

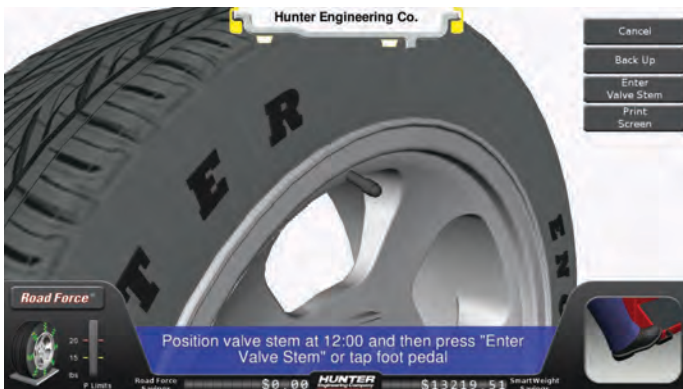

Figure 89.

CenteringCheck® results will appear

If the rim is centered properly, the CENTERING CHECK PASSED screen will appear. (Figure 98.)

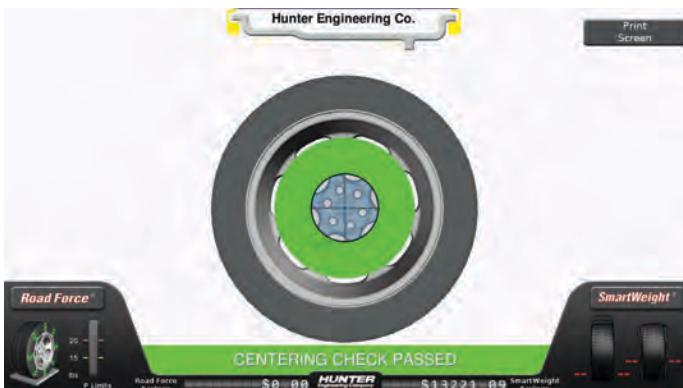

Figure 90.

The balancer will then return to the main balance screen. Balancing procedures may now be performed.

If a centering problem is detected, the "off-target" screen will be displayed. (Figure 99.)



Figure 91.

The CenteringCheck® procedure will repeat up to four times and always compare the previous measurement to the next check.

If centering is not achieved after four attempts, the CENTERING FAILURE screen will appear. (Figure 100.)



Figure 92.

If centering is not achievable, check for:

- Correct collet/adaptor for this wheel design.
- Wheel defect such as a metal burr interfering with the cone/adaptor.
- Dirt or debris interfering with the cone/adaptor.

Follow the on-screen prompts, and then touch the "Restart Procedure" button.

Mounting Error Detection Features

To verify that the tire/wheel assembly is centering, remount the tire/wheel assembly and observe the results. Do any of the following conditions occur?

- Weight amount varies excessively
- Weight location changes

If any of these conditions occur, the centering accuracy of the tire/wheel assembly needs to be verified.

3.4 Front / Back Collet Mounting

Collet mounting is one of the most common and reliable ways to mount wheels on balancers.

The Bullseye™ Centering System is a set of collets that provides wheel centering coverage for most passenger cars and light trucks. Due to the degree of taper on the collets, multiple collets may be used on a wheel assembly. As long as the collet is in the center bore of the wheel, and does not bottom out, it can be used. To verify, always perform a centering check.

Select the proper Bullseye Centering System™ collet by placing it in the center bore of the wheel to be balanced. Select the collet that contacts the wheel nearest the center of the collet. (Figure 101.)

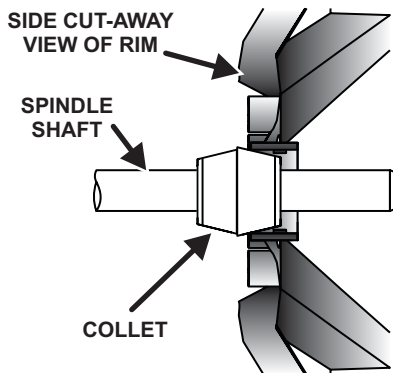

Figure 93.

i When using a collet, make sure that only the sloping surface contacts the center wheel bore. If the face of collet “bottoms out” on the interior surface of the rim, choose a different collet (Figure 102.)

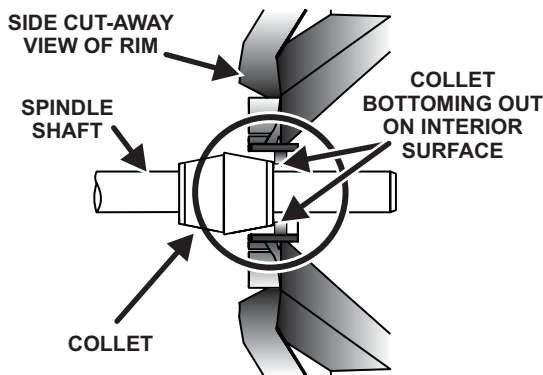

Figure 94.

Place the wheel collet on the spindle shaft against the spring plate. Mount the wheel with the inner rim facing the balancer and centered on the collet.

i Use only the wing nut or SpeedClamp™ supplied with the balancer.

Install the clamping cup and wing nut / SpeedClamp™ on the spindle shaft against the wheel and secure the entire assembly as previously described. (Figure 103.) and (Figure 104.)

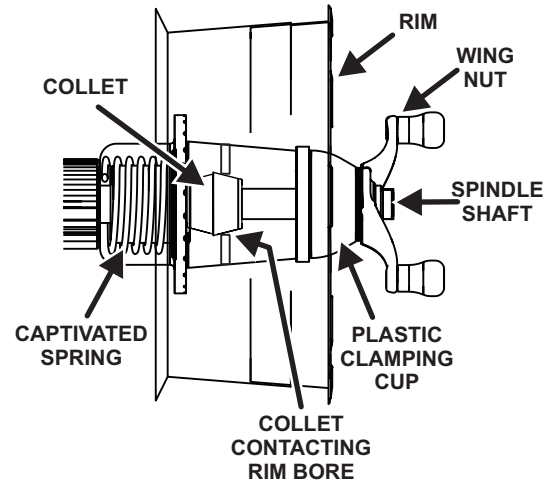

Figure 95.

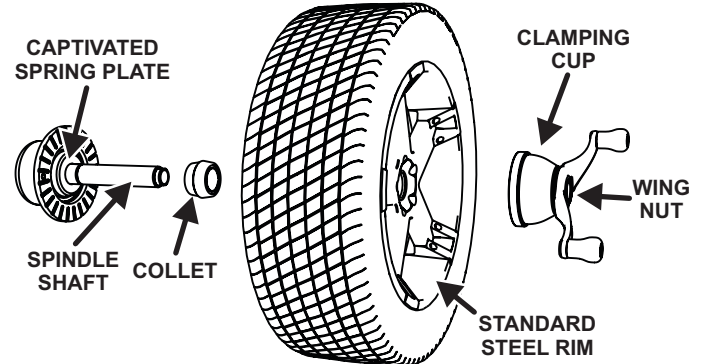

Figure 96.

Using The Plastic Wheel Mounting Spacer

The plastic wheel mounting spacer, 46-320-2, may be used to prevent scratches on wheels where the standard plastic cup and scratch guard cannot be used.

The plastic wheel mounting washer may also be used when mounting a wheel with a large offset that is between collet sizes. Use of the washer as shown below can improve centering ability by increasing cone pressure against the wheel.

For example: One collet size is too small because the captivated spring is not pressing the collet against the inner wheel opening, but the next larger collet size is too big and will not fit the opening. Use the smaller collet size with the plastic wheel mounting washer to “extend” the captivated spring to hold the collet against the wheel opening with greater pressure. The scratch guard may be installed on the clamping cup to protect alloy rims from

being marred, but should not be used on steel wheels. (Figure 105.) and (Figure 106.)

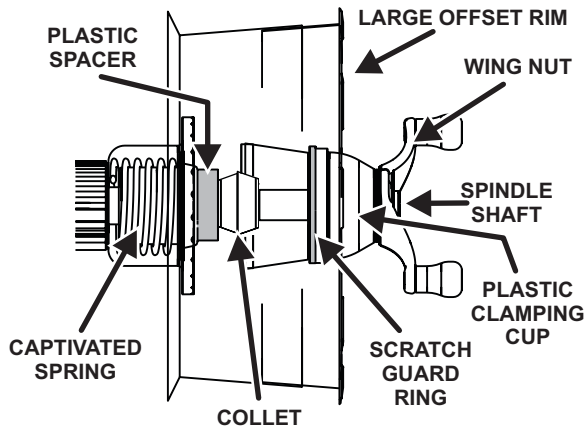

Figure 97.

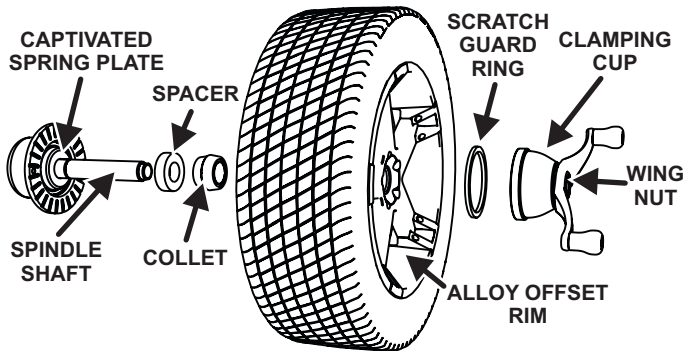

Figure 98.

Using The 9-Inch Alloy Wheel Pressure Cup

In some cases, the wing nut / SpeedClamp™ contact point of the wheel may be extremely wide, and the standard clamp cup will not properly contact the wheel hub area. In these cases, the optional nine inch alloy wheel pressure cup may be used in place of the clamping cup. (Figure 107.)

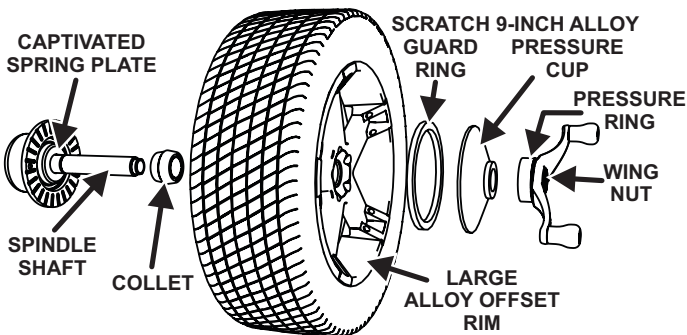

Figure 99.

Front Collet Mounting

i Front collet mounting is generally not recommended. It should only be used in instances where traditional backside collet mounting is not possible.

This procedure utilizes a collet inserted from the front side of the wheel instead of the backside as previously described.

Select the proper collet by placing it in the center bore of the wheel to be balanced. Choose the collet that contacts the wheel nearest the center of the collet.

Mount the wheel with the inner rim facing the balancer. Place the collet on the spindle with the appropriate side of the collet facing the front of the wheel.

Install the wing nut / SpeedClamp™ and pressure ring assembly onto the spindle shaft against the wheel and secure the entire assembly by firmly tightening the wing nut or / SpeedClamp™. (Figure 108.)

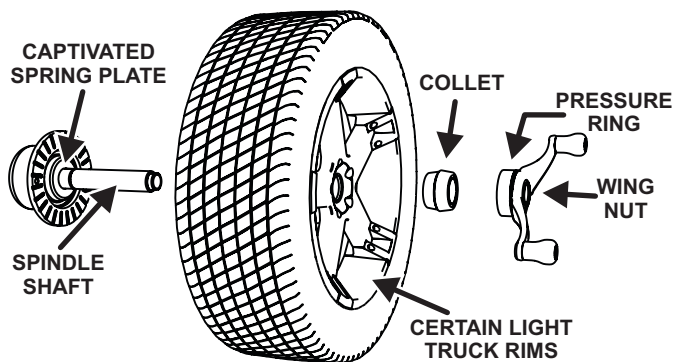

Figure 100.

Heavy Wheel Centering

Heavy wheel centering may benefit by (1) pulling the tire away from the hub face at top dead center while tightening the wing nut or (2) use of optional wheel lift to position heavy wheel onto shaft and cone. This helps the wheel to overcome gravity against the hub or spacer.

3.5 Specialized Mounting Conditions

Collet / Flange Plate Mounting

Some wheels may be centered using the lugholes and center bore with a flange plate and collet. It is important that a back mounted collet be used to support and center the wheel when using flange plates. (Figure 109.)

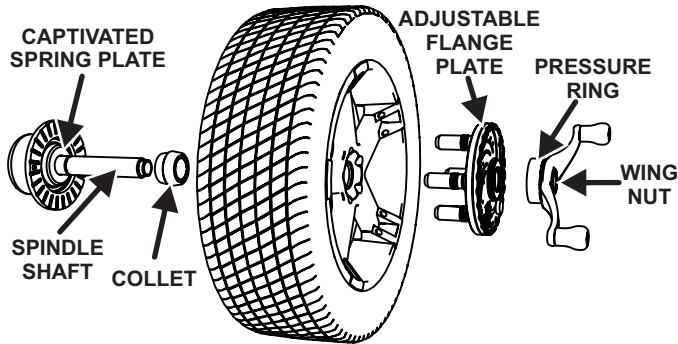

Figure 101.

The correct flange adaptor setup is determined by the following:

Measure and set the bolt circle diameter and number of studs to use against the lug holes.

Set the number of lugholes as follows:

A three-lug wheel uses three studs.

A four-lug wheel uses four studs.

A five-lug wheel uses five studs.

A six-lug wheel uses three studs.

A seven-lug wheel uses seven studs.

An eight-lug wheel uses four studs.

Choose the correct taper design of flange studs to fit the wheel lug seats. The mounting area of the flange stud must match the design of the wheel's lughole seat or depression.

The flange plate must be able to apply pressure to the center of the wheel while maintaining perpendicularity to the shaft.



If the lug seats are unevenly machined or worn, an optional universal flange adaptor with compressible studs or bolt on lugs may be used to more accurately mount the wheel with the collet.

Flange plates are useful when the wheel cannot be properly centered off the hub bore with a collet alone

because of improper fit, interference, or lack of a center hole.

A flange plate in many cases adds value because it aids in more effective centering than a collet alone. This statement is true for many wheels including hub centric wheels. That is why a flange plate and back cone may be more accurate and repeatable, regardless of whether the wheel is lug centric or hub centric.

Expandable Collet Mounting

An expandable collet should NOT be used with the Road Force® / GSP9700 due to the amount of force applied by the load roller.

Using the Pressure Ring and Spacers

Pressure Ring

The pressure ring clips on to the wing nut. It is used in lieu of the clamping cup.

It may also be used in place of a clamping cup if space is limited between the wheel and the end of the spindle.

The pressure ring should be used to prevent the wing nut from directly contacting an adaptor or a collet. It will act as a bearing to enable higher clamping forces. (Figure 110.)

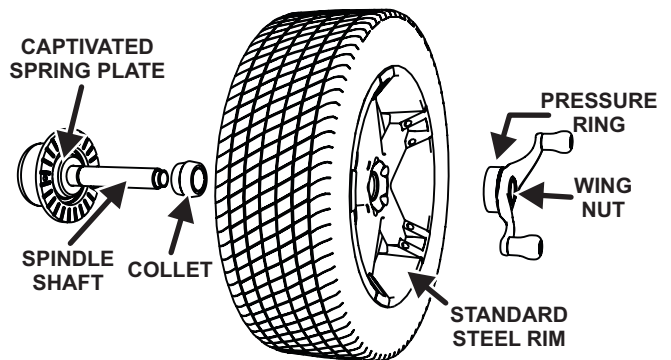

Figure 102.

Hub Ring Spacers

These spacers are designed to build a larger pocket when using extra large collets. It also provides a location for the centering pins found on some dual wheel configurations. (Figure 111.)

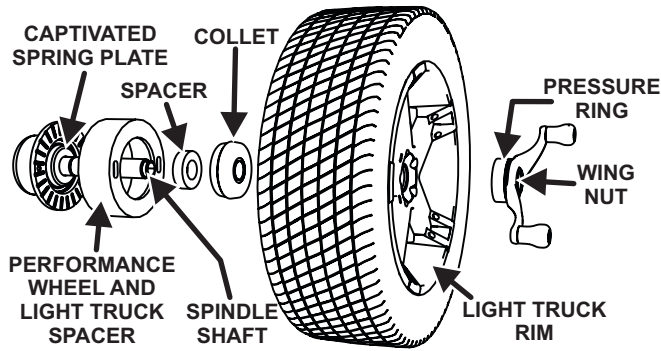

Figure 103.

3.6 On-Vehicle Wheel Installation Methods

Hub Centric

A hub centric wheel is aligned to the hub by the center bore of the wheel. The vehicle weight rests on the hub bore. The clearance between the hub bore and the hub on a hub centric wheel is between 0.003 and 0.004 of an inch. A hub centric wheel is identified by removing the lug nuts (or bolts) and moving the wheel up, down, and side-to-side. If there is virtually no movement or shift, the wheel is centered by the hub. (Figure 112.)

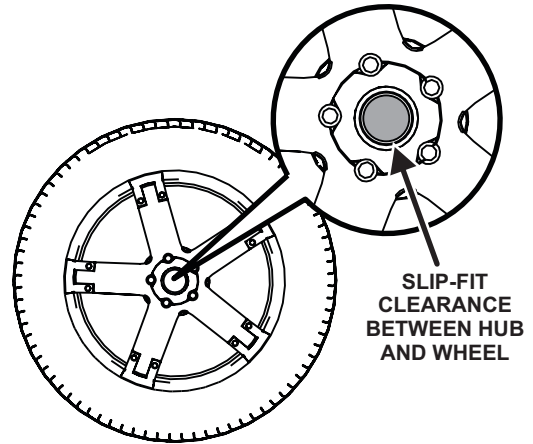

Figure 104.

To verify if the wheel is hub centric:

Remove the lug nuts (or bolts) and try to move the wheel up/down and side/side on the hub.

If the wheel has no appreciable movement around or about the centerline of the hub, it should be considered hub centric.

A hub centric wheel will have very little (0.003 – 0.004”) clearance or a slip fit to the hub.

Lug Centric

A lug centric wheel is identified by removing the lug nuts (or bolts) and moving the wheel up, down, and side-to-side. If movement around the hub is apparent, the wheel is centered on the vehicle by the lugs or studs of the axle flange. (Figure 113.)

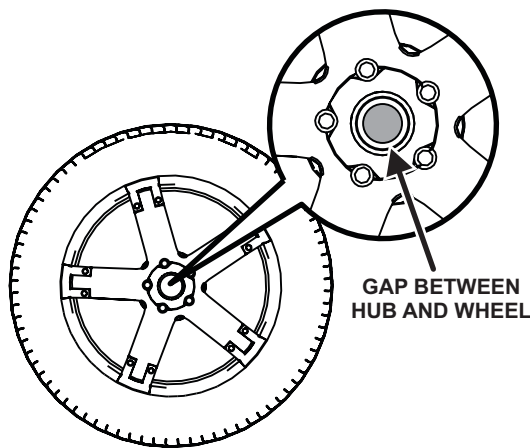

Figure 105.

The static imbalance and radial force variation of a lug centric wheel may be greatly changed when the centering of the wheel differs on the vehicle.

To verify if the wheel is lug centric:

Remove the lug nuts (or bolts) and try to move the wheel up/down and side/side on the hub.

A lug centric wheel will display noticeable movement.

Use “Step-torque” star pattern to proper torque specification.



When mounting a lug centric wheel to a vehicle, extreme centering care must be taken by ensuring the lug nuts (bolts) are tightened equally, while rotating the wheel. (Figure 114.)

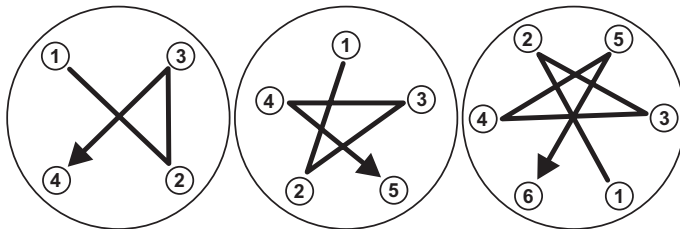

Figure 106.

3.7 Wheel Assembly Selection for Saving Spin Data

Saving Spin Data

The Road Force® Elite GSP9700 automatically tracks the wheel assembly currently being balanced.

The balancer assumes that the technician is working “around the vehicle” by beginning at the LEFT FRONT and working around the vehicle in a clockwise fashion. Successive spins are stored as either “before” or “after” data based on the following rules:

- If the weight displays read “OK/OK” or is blank, assume the next complete spin is “before” data. (Figure 115.)



Figure 107.

- If the weight displays read anything other than “OK/OK” or is blank, assume the next complete spin is “after” data.

Measurement Storage

The Road Force® Elite GSP9700 automatically tracks the wheel assemblies as they are balanced.

As the wheel assemblies are balanced, their status can be viewed as they would appear on the vehicle currently being serviced. Select the VirtualView® button to expand the VirtualView® panel. (Figure 116.)



Figure 108.

The panel can be further expanded to show detailed information for up to the last eight wheel assemblies balanced. (Figure 117.)

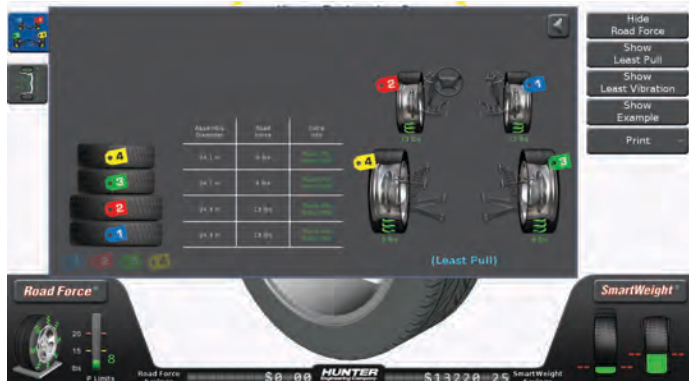

Figure 109.

Print Summary

A printout is available that incorporates a detailed image of each wheel assembly with the stored measurements. If a measured value is out of tolerance compared to the recalled specification, the value will be printed in red.

From the main balance screen, select "Print". (Figure 118.)



Figure 110.

From the drop down menu, select "Vehicle Summary". (Figure 119.)

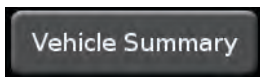

Figure 111.

The Vehicle Summary screen will be displayed. (Figure 120.)

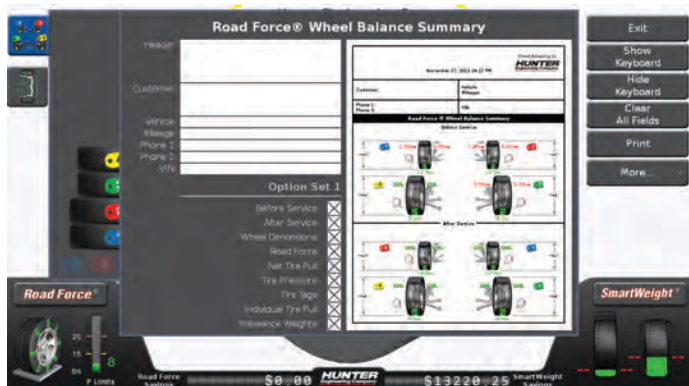

Figure 112.

From this screen, several options may be used to create custom printouts. Information such as the shop name, customer name, vehicle, etc., can be displayed on the printout. (Figure 121.)

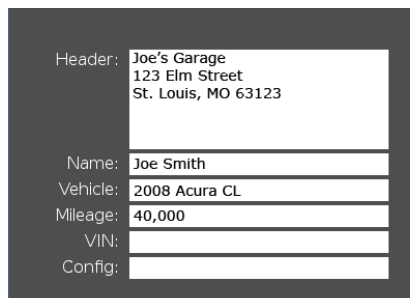

Figure 113.

Information for the printout can be entered using the on-screen keyboard. (Figure 122.)



Figure 114.

Also, custom data such as before service, after service, individual tire pull, etc., can be toggled on or off for the printout. (Figure 123.)

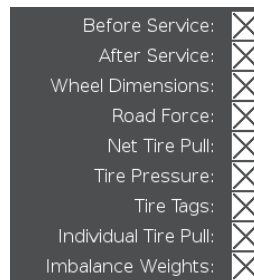

Figure 115.

Once the options are set for the printout, they can be stored and recalled later. (Figure 124.)

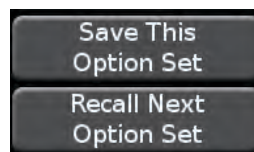

Figure 116.

Select "Recall Next Option Set" to cycle to the next set. (Figure 125.) and (Figure 126.)



Figure 117.



Figure 118.

Select "Print" to send before and after balance summary results to the printer. (Figure 127.) and (Figure 128.)



Figure 119.

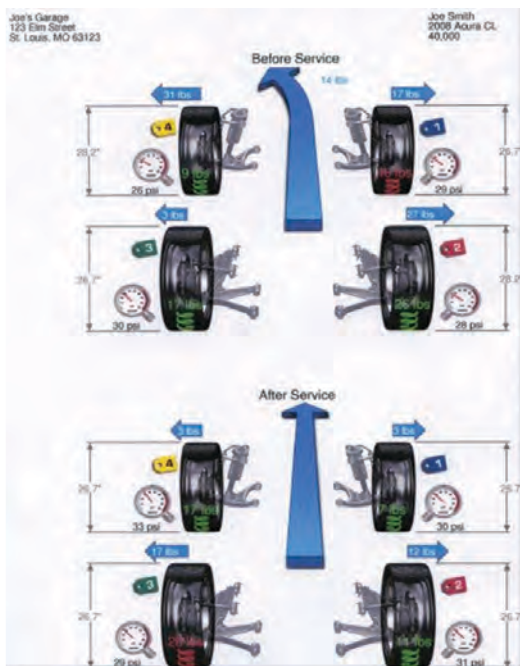

Figure 120.

Single Assembly Road Force® Printouts

The Road Force® Elite GSP9700 allows for single wheel assemblies to be printed for situations when Road Force® is only needed for a single wheel.

Select "Print" to send before and after balance summary results to the printer. (Figure 129.) and (Figure 130.)



Figure 121.



Figure 122.

3.8 Balance Modes

SmartWeight Balancing Technology®



SmartWeight Balancing Technology® is a method of reducing forces on a wheel during balancing. SmartWeight® is not a procedure. Instead, it measures the forces of side-to-side movement and up-and-down shake and computes weight to reduce these forces. This reduces the amount of correction weight used, balancing time required, check spins needed and “weight chasing”.

SmartWeight® saves the shop time and money.



Figure 123.

Dynamic Balancing – Traditional Balancing Mode

i SmartWeight Balancing Technology® is the default balancing method and is the most recommended way to accurately balance wheel / tire assemblies.

i Enter wheel dimensions before selecting dynamic balancing. If SmartWeight® mode is enabled in setup, the balancer will return to SmartWeight® balancing upon dimension entry.

Dynamic balancing will always display two weight planes. It provides a more complete balance than static balancing. Dynamic balancing should be selected whenever possible to minimize vehicle vibration.

Switching from SmartWeight Balancing Technology® to Traditional Dynamic Balancing

At any time, SmartWeight Balancing Technology® can be switched to standard balancing provided that both

standard and SmartWeight® balancing modes are enabled in setup.

Touch the SmartWeight® button to display the SmartWeight® menu buttons. (Figure 132.)

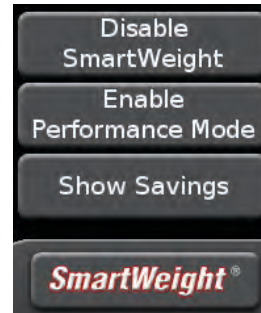

Figure 124.

Select the Disable SmartWeight® button. (Figure 133.)



Figure 125.

The balancer is now in traditional dynamic balancing mode. (Figure 134.)



Figure 126.

i When changing to traditional dynamic balancing mode, weight amounts as well as weight placement locations change. (Figure 135.) and (Figure 136.)



Figure 127.



Figure 128.

Static Balancing – Traditional Balancing Mode

 Enter wheel dimensions before selecting dynamic balancing. If SmartWeight® mode is enabled in setup, the balancer will return to SmartWeight® balancing upon dimension entry.

Static balancing provides a less desirable balance than dynamic balancing. Dynamic balancing should be selected whenever possible to minimize vehicle vibration.

Switching from Traditional Dynamic Balancing to Traditional Static Balancing.

In non-SmartWeight® mode, the balancer can be switched from dynamic balancing to static balancing.

Dynamic mode is selected: (Figure 137.)



Figure 129.

Touching the static mode icon will switch to static mode. (Figure 138.)



Figure 130.

Blinding and Rounding

In non-SmartWeight® mode, the balancer can display either an “actual” or “blinded and rounded” amount of imbalance.

Touching the magnifying glass icon next to the dynamic or static icons will toggle blinding and rounding on or off.

Dynamic mode, blinding/rounding is disabled: (Figure 139.)



Figure 131.

Static mode, blinding/rounding is enabled: (Figure 140.)



Figure 132.

3.9 Balancing Procedures for Specific Weight Types and Placement using TruWeight™

The Road Force® Elite GSP9700 offers both automatic and manual modes for weight placement.



Figure 133. Automatic Mode



Figure 134. Manual Mode

Clip-clip, tape-tape and mixed weight modes are available for both dynamic and static balancing.

With these options, correction weights can be placed at an infinite number of locations, based upon the choice of the operator.

Automatic is the default setting, automatically choosing the correct type of weights and locations determined by optical scan.

TruWeight™ shows the operator exactly how to place the weights on the wheel. Place them exactly as displayed on the screen.

SmartScan™ Dimensions Entry

From the main balance screen, the operator can take wheel dimensions using SmartScan™ dimension entry. This is done automatically by SmartScan's™ inner and outer cameras when lowering the hood and performing a balance spin. Runout, rim dimension, spoke and weight plane location, as well as the wheel weight type (either clip or tape) are calculated automatically by SmartScan™ on every spin.



If a wheel weight type other than what is determined by SmartScan™ is desired, users may touch a different weight plane to change weight type.



Incorrect or missing spoke locations do not affect the balancer's ability to properly balance wheels. Rim profile calculations are performed separately from spoke identification. This can be verified by comparing the appearance of the 3D generated profile to the actual wheel. Simply touch the "Enter Spokes" button and enter spoke locations manually to correct spoke identification errors.

Single Weight Placement

Occasionally, regardless of the weight mode, a single tape weight is shown in the middle of the wheel. Place the weight as shown on-screen. The crucial task is to line up the center of the weight with the laser line. The depth of placement does not need to be exact, use features of the rim profile to determine the location.

Balancing Procedure Using Clip-On Weights

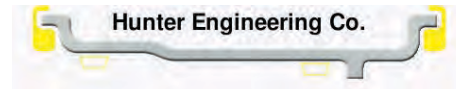

Figure 135.

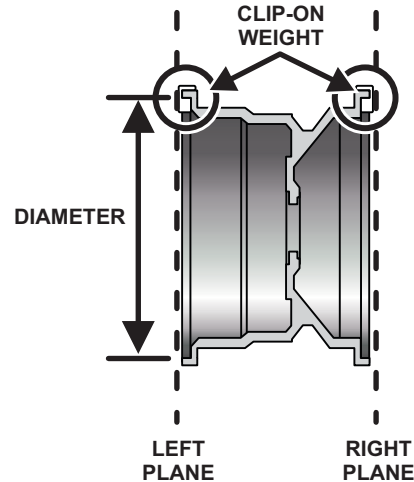

Figure 136.

Verify the correct clip-on weight type will be used for the wheel that is being balanced.

Verify that the wheel is clean and free of debris.

Remove all previous weights.

Mount tire/wheel assembly.

Close safety hood.

Touch the green "START" button if "Hood Autostart" is disabled.

As the wheel is spinning, the amount(s) of corrective weight(s) needed will be shown on the screen. This time can be used to find and prepare the needed weights.



Once weight amounts are shown on the screen, they can be toggled to display either ounces or grams by pressing the "oz" or "g" graphic shown after the weight amount. (Figure 145.)



Figure 137.

After wheel comes to a complete stop, raise the safety hood.



If Auto Hood is enabled, the hood will raise automatically.

The Road Force® Elite GSP9700 will find the top-dead-center (TDC) for the first weight plane if “Servo-Stop” is enabled. “Servo-Stop” will hold the wheel in the TDC position while the weight is applied. (Figure 146.)



Figure 138.

Attach the weight amount shown on the screen for the selected weight plane to the correct side of the wheel.

TruWeight™ shows the operator exactly how to place the weights on the wheel. Place them exactly as displayed on the screen. (Figure 147.)



If the optional HammerHead® TDC weight locator is installed, the weight should be applied at the location marked by the laser.

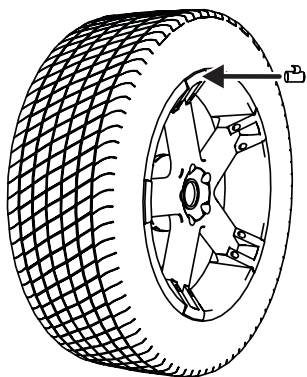

Figure 139.

Touch the green “START” button with the safety hood in the raised position. (Figure 148.)



Figure 140.

The Road Force® Elite GSP9700 will rotate the wheel to TDC for the next weight plane. The view of the wheel will also change to the next plane view and the weight amount for the next plane will be displayed in green. (Figure 149.)



Figure 141.



Optionally, pressing the next plane weight amount will rotate the wheel to TDC for the next weight plane.

Attach the weight amount shown on the screen for the selected weight plane to the correct side of the wheel.

TruWeight™ shows the operator exactly how to place the weights on the wheel. Place them exactly as displayed on the screen.

(Figure 150.)



If the optional HammerHead® TDC weight locator is installed, the weight should be applied at the location marked by the laser.

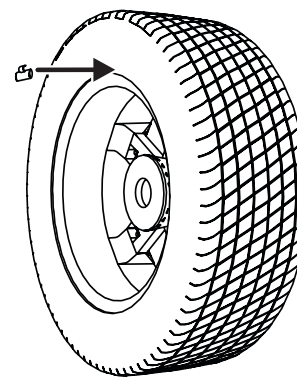

Figure 142.

Close the safety hood to perform a check spin.

Left and right weight plane displays should show “OK” after the check spin. (Figure 151.)



Figure 143.

The clip-on weight balancing procedure is complete.

Balancing Procedure Using a Combination of Clip-On & Adhesive (Tape) Weights (Mixed Weights)

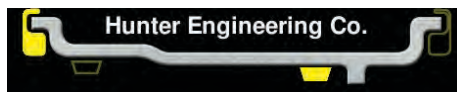

Figure 144.

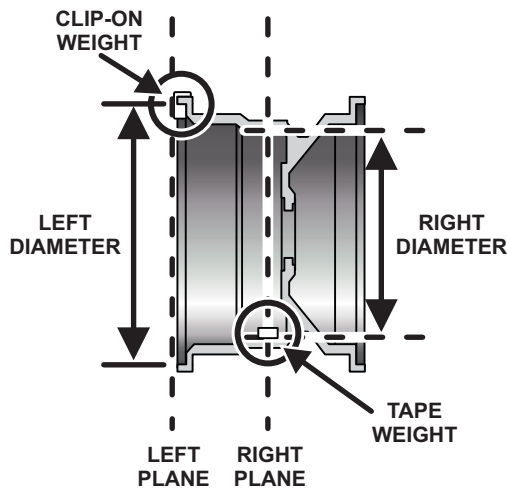

Figure 145.

Verify that the wheel is clean and free of debris.

Remove all previous weights.

Mount tire/wheel assembly.

Close the hood to perform a balance spin to measure the distance, diameter, runout and rim width dimensions.

As the wheel is spinning, the amount(s) of corrective weight(s) needed will be shown on the screen. This time can be used to find and prepare the needed weights.

i Once weight amounts are shown on the screen, they can be toggled to display either ounces or grams by pressing the “oz” or “g” graphic shown after the weight amount. (Figure 154.)



Figure 146.

After wheel comes to a complete stop, raise safety hood.

i If Auto Hood is enabled, the hood will raise automatically.

The Road Force® Elite GSP9700 will find the top-dead-center (TDC) for the first weight plane if “Servo-Stop” is enabled. “Servo-Stop” will hold the wheel in the TDC position while the weight is applied. (Figure 155.)



Figure 147.

Attach the clip-on weight amount shown on the screen for the left weight plane to the inner rim of the wheel.

TruWeight™ shows the operator exactly how to place the weights on the wheel. Place them exactly as displayed on the screen.

(Figure 156.)

i If the optional HammerHead® TDC weight locator is installed, the weight should be applied at the location marked by the laser.

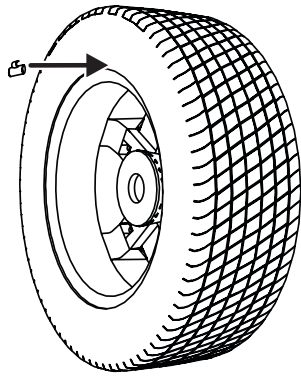



Figure 148.

Touch the green “START” button with the safety hood in the raised position. (Figure 157.)



Figure 149.

 Optionally, pressing the next plane weight amount will rotate the wheel to the next weight plane.

The Road Force® Elite GSP9700 inner camera quickly locates and marks adhesive weight positioning. (Figure 158.)



Figure 150.

The laser locator automatically displays a vivid line at bottom dead center after a wheel has been spun. The laser turns off when the wheel is spun again.

 **Caution!** Use of controls or adjustments or performance of procedures other than those specified herein may result in hazardous radiation exposure.

With the servo enabled, attach the adhesive weight using the weight amount shown for the right weight plane on the screen.

TruWeight™ shows the operator exactly how to place the weights on the wheel. Place them exactly as displayed on the screen.

Close the safety hood to perform a check spin.

Left and right weight plane displays should show “OK” after check spin. (Figure 159.)



Figure 151.

MIXED WEIGHTS balancing procedure is complete.

Balancing Procedure Using Adhesive (Tape) Weights

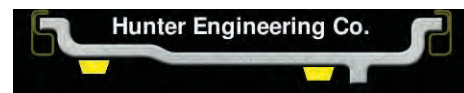

Figure 152.

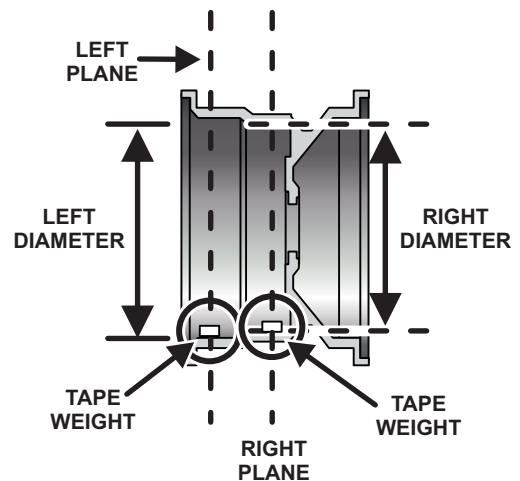

Figure 153.

Verify that the wheel is clean and free of debris.

Remove all previous weights.

Mount tire/wheel assembly.

Close the hood to perform a balance spin. Information is computed automatically.

As the wheel is spinning, the amount(s) of corrective weight(s) needed will be shown on the screen. This time can be used to find and prepare the needed weights..

i Once weight amounts are shown on the screen, they can be toggled to display either ounces or grams by pressing the “oz” or “g” graphic shown after the weight amount. (Figure 162.)



Figure 154.

After wheel comes to a complete stop, raise the safety hood.

i If Auto Hood is enabled, the hood will raise automatically.

The Road Force® Elite GSP9700 Servo-Activated Laser automatically locates adhesive weight positioning. (Figure 163.)



Figure 155.

The laser weight locator automatically displays a vivid line after a wheel has been spun. The laser turns off when the wheel is spun again.

! Caution! Use of controls or adjustments or performance of procedures other than those specified herein may result in hazardous radiation exposure.

With the servo enabled, attach the adhesive weight using the weight amount shown for the left weight plane on the screen.

TruWeight™ shows the operator exactly how to place the weights on the wheel. Place them exactly as displayed on the screen.

Touch the green “START” button with the safety hood in the raised position. (Figure 164.)



Figure 156.

i Optionally, pressing the next plane weight amount will rotate the wheel to the next weight plane.

Close the safety hood to perform a check spin.

Left and right weight plane displays should show “OK” after the check spin. (Figure 165.)



Figure 157.

ADHESIVE WEIGHTS balancing procedure is complete.

Enable Dragging Feature

The Enable Dragging feature allows the user to drag tape weights to a specific area of the wheel where he or she would like to place weights.

Touch the “Measurements” icon on the left side of the screen after a balance spin. Touch the “Enable Dragging” button on the right hand side of the screen.



Figure 158.

Users can now drag the tape weight(s) as desired.

3.10 Blinding and Rounding

In non-SmartWeight® mode the balancer can display either an “actual” or “blinded and rounded” amount of imbalance.

“Blind” is a tolerance or amount of imbalance required before an imbalance amount is displayed. “Round” allows the balancer to display weight imbalance to a desired increment. The blind and round values can be changed in the “Setup” procedure.

While in the “Balance” primary screen, blind and rounding may be disabled by touching the screen to highlight the magnifying glass. The actual amounts of imbalance for the selected mode will be displayed when “Blind and Rounding” are disabled as shown below.

Dynamic mode, blinding/rounding is disabled: (Figure 167.)



Figure 159.

Static mode, blinding/rounding is enabled: (Figure 168.)



Figure 160.

3.11 Tape Weight Menu

By touching a weight on the wheel, such as the strips of weight shown below, a weight style menu will appear. (Figure 169.) and (Figure 170.)



Figure 161.



Figure 162.

This offers the ability to change to another style of tape weight and/or split the weight. This can improve balancing accuracy.

Here, the 1/2 oz style weights were selected by touching that weight on the screen. (Figure 171.)



Figure 163.

Additional properties of the available weight styles are considered in the calculations so that chase spins are avoided. It is even possible for a menu choice to change the total required weight size to place on the wheel. Unlike previous balancers, the weight properties

and placement arrangements are not assumed by the calculations. The ability to “tell” the balancer what you are using and doing avoids time consuming weight chasing.

The weight menu won’t always provide a choice using single row weights.

Showing a single weight as a second row may seem odd, but it saves effort before and after applying the weights. To trim a single strip of 1/2 oz weights to 3.75 oz is tedious enough, but to center that trimmed length on the laser line would be even harder.

Placing the strip of 1/2 oz weights first and then the single 1/4 oz weight is faster more accurate. This mixed use of weight strip styles is no problem since the balancer knows exactly what styles are used and how the pieces are arranged.

Split Weight®

The split weight® software fans the weight on selected plane into two smaller weights. (Figure 172.)



Figure 164.

If the servo is on at the time of the split, the wheel will move one of the split weights to near BDC and turn on the laser for weight placement. Repeated touches of “Split the Weight” will provide alternate choices where the weights fan further apart but become larger to accommodate the correction needed.

To return to the single weight, touch “Split the Weight” repeatedly until the weights become larger than the single weight and return to the un-split weight. (Figure 173.)



Figure 165.

Correcting Large Imbalances

Split Weight® can also be used to apply three weights when needed. For example, a large wheel may require 6.75 ounces. Not only is this size unlikely to be in the weight tray, but splitting 6.75 ounces would likewise result in large weights. In this case, apply one-third of the called for weight (in this case 2.25 ounces) at the 6.75 ounce weight location and spin the assembly again. The display will now call for a 4.5 ounce weight to be placed on top of the 2.25 ounce weight.

Touch “Split the Weight” to fan out the two weights until they clear the previously applied 2.25 ounce weight. Then place the two indicated ounce weights on either side of the 2.25 ounce weight using the TDC indicators.

3.12 Split Spoke® Feature

When in either mixed weight or adhesive weight modes, (dynamic or static), correction weights can be hidden behind the spokes of a wheel.

If the Split Spoke® feature of hiding weights behind spokes is to be used, touch the Split Spoke tab. Follow the on screen instructions.

Move to the next spoke and repeat. 2 spoke locations are be entered.

Continue the balance procedure as normal.



When SmartWeight® is enabled in conjunction with wheel spoke entry, the “SmartSpoke®” weight locator feature can in many instances allow the use of weight at only one spoke when it would have required two using conventional spoke mode balancing.

3.13 Optional HammerHead® TDC Laser Clip-On Weight Locator

The balancer will find the TDC for the left or right weight plane if “Servo-Stop” is enabled. “Servo-Stop” will hold the wheel in the TDC position while the servo-activated laser automatically locates TDC to aid in fast clip-on weight positioning.

The HammerHead® TDC Laser System automatically displays a vivid line at top dead center after a wheel has been spun. The laser turns “off” when the wheel is spun again.



Caution! Use of controls or adjustments or performance of procedures other than those specified herein may result in hazardous radiation exposure.

This Laser Product is designated as Class 2M during all procedures of operation.

Never look directly into the laser. Doing so may cause serious injury.



Figure 166.

Operation accessible radiation fields:

Wavelength: 635-660nm

Laser Power for Classification: <1mW via 7mm aperture

Beam Diameter: <5mm at aperture

Divergence: <1.5mrad x <2rad

Transverse Beam Mode: TEM00

Specific Precautions / HammerHead® TDC Laser System

Use caution in regard to reflective materials around the laser and never look into the laser beam



Figure 167.

! Use of controls, adjustments, or performance of procedures other than those specified herein may result in hazardous radiation exposure.

This Laser Product is designated as Class 2M during all procedures of operation.

Do not stare into the beam or view directly with optical instruments. Doing so may cause serious injury.

Do not intentional use a reflective device to enhance or re-direct the laser.

Do not operate the laser if the cover or seal is damaged.

There is no required maintenance or service to keep the HammerHead™ TDC Laser System in compliance.

The laser is not a field serviceable or an adjustable part.

Any necessary repair or maintenance should be done by the factory only. The HammerHead™ TDC Laser System has no field serviceable parts.

The unit should never be opened or modified.

3.14 TPMSpecs™ Feature

i TPMS specifications can also be found on Hunter Aligners (with WinAlign 11.0 and greater) and online at UnderCarInfo.NET (subscription service).

The TPMSpecs® feature identifies vehicles with tire pressure monitoring systems. It also provides in-depth information regarding the service of TPMS.

- TPMS Type
- Sensor Type
- Reset Required on Tire Rotation or Replacement
- Reset Tool Requirement
- Required Tools
- Reset Procedure
- TPMS Hints
- Information / Disclaimers

TPMSpecs® may be accessed in two ways.

Option 1:

From the Main Balance screen, scan a VIN barcode. TPMS information for the vehicle scanned will be automatically retrieved and displayed.

Option 2:

From the main balance screen, touch the “Tools” button. (Figure 176.)



Figure 168.

Touch the “TPMS” button. (Figure 177.)



Figure 169.

The main TPMSpecs® screen is displayed. Select the make, model and specifics of the vehicle being serviced. (Figure 178.), (Figure 179.) and (Figure 180.)



Figure 170.



Figure 171.



Figure 172.

The "AT A GLANCE" overview starts each vehicle TPMS specification. The first image shows the type of TPMS sensor on the vehicle. The following three images show the requirements for servicing the wheel: process, scan tool and OEM scanner. The red border, yellow border or grayed appearance of the image denotes the requirement as required, optional or not required. Red and white striped border indicates the requirement is possibly required; refer to the explanation below the images. (Figure 181.)



Figure 173.

Scroll up or down by dragging the scroll bar, or touching the "up" and "down" arrows on the right side of the screen. (Figure 182.)



Figure 174.

Touch the "Home" button to return to the main TPMSpecs® Menu. (Figure 183.)



Figure 175.

Touch the "arrows" to navigate backward or forward. (Figure 184.)

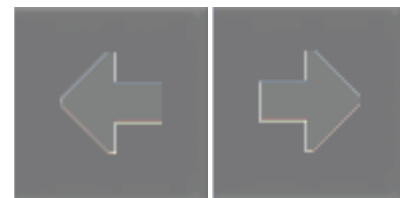

Figure 176.

Touch the “print” button to print the current page.
(Figure 185.)



Figure 177.

Touch “X” to return to the balancer screen. (Figure 186.)



Figure 178.

3.15 Hunter Help

Video Player

The Video Player feature provides tips and procedures for using the Road Force® Elite GSP9700.

To access the Video Player:

From the main balance screen, touch the “Help” button.(Figure 187.)



Figure 179.

Touch the “Launch Video Player” button.
(Figure 188.)



Figure 180.

The main video menu screen is displayed. (Figure 189.)

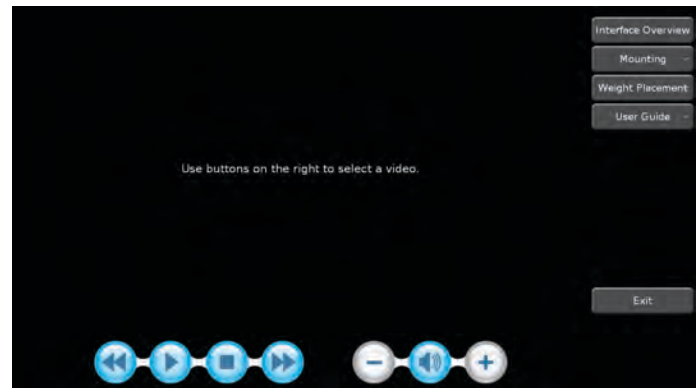

Figure 181.

Select a topic from the menu to view the video.
(Figure 190.)

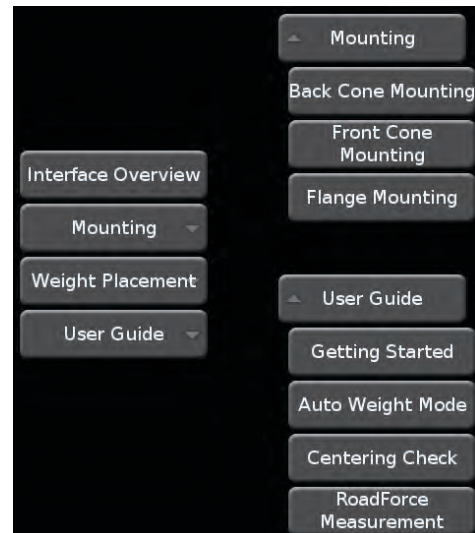

Figure 182.



The video screens may change as new content is added.

The selected video will begin playing. (Figure 191.)



Figure 183.

Go back in the video by touching the “back” button. (Figure 192.)



Figure 184.

Play the video by touching the “play” button. (Figure 193.)



Figure 185.

Stop the video by touching the “stop” button. (Figure 194.)



Figure 186.

Go forward in the video by touching the “forward” button. (Figure 195.)



Figure 187.

Decrease the video volume by touching the “-” button. (Figure 196.)



Figure 188.

Mute the video volume by touching the “mute” button. (Figure 197.)



Figure 189.

Increase the video volume by touching the “+” button. (Figure 198.)



Figure 190.

Exit the video player by touching the “Exit” button. (Figure 199.)

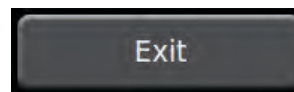

Figure 191.

Launch Help

The Hunter Help feature provides tips and procedures for Hunter balancers and tire changers. It also provides a Rolling Smooth Sample Quiz.

Additional content will be added to the Hunter Help files and can be updated as it becomes available.

To access Hunter Help:

From the main balance screen, touch the “Help” button. (Figure 200.)



Figure 192.

Touch the “Launch Help” button. (Figure 201.)

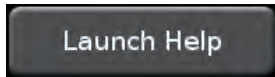

Figure 193.

The Main Menu of Hunter Help is displayed. Select the item to view by touching the selection. (Figure 202.)

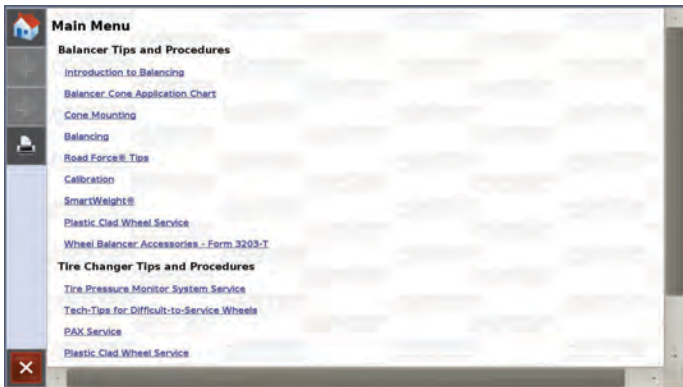

Figure 194.



The help screens may change as new content is added.

Some items have sub-menus that will display help on a specific topic. Touch to view the selected topic. (Figure 203.)



Figure 195.

Detailed help on specific topics can also be printed. Select “Print” to print the page currently being viewed. (Figure 204.)

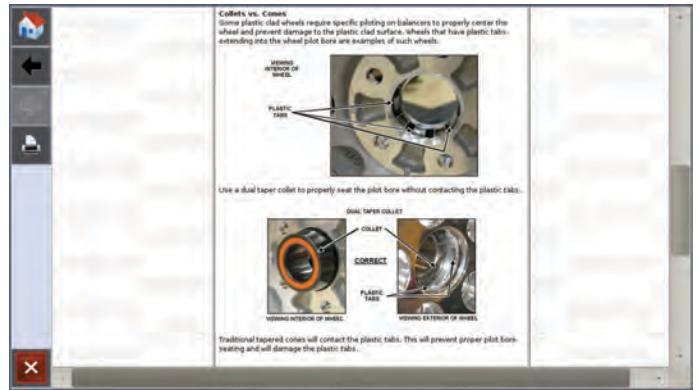

Figure 196.

4. Road Force Measurement[®] Procedures

4.1 Load Roller Operation

The load roller runs parallel to the tire and applies a perpendicular load on the assembly to take information required for the Road Force Measurement[®] system. It is capable of applying up to 1400 pounds of force. The amount of force placed on the tire is dependent upon the tire's diameter and stiffness. The load roller will not overload the tire.



It is important that the air pressure of the tire is set to specifications prior to using the Road Force Measurement[®] system. Incorrect tire pressure will affect the results. If the Road Force[®] Elite GSP9700 is equipped with the Inflation Station feature, the tire can be easily set to the specified air pressure.

The load roller can be enabled and disabled by touching the load roller on the screen. When the load roller is enabled, the screen will display the load roller with enabled settings. (Figure 206.)



Figure 197.

When the load roller is disabled, a red "X" appears on the load roller. (Figure 207.)



Figure 198.

The load roller can also be enabled and disabled by touching the Road Force[®] button then touching the "Toggle Roller" button. (Figure 208.) and (Figure 209.)



Figure 199.

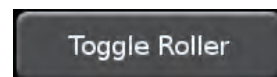



Figure 200.

Road Force® with Limits Enabled

When the load roller is enabled, “LT Tires,” “P-SUV Tires,” or “P Tires” Road Force® limits can be changed.

Changing the “LT Tires,” “P-SUV Tires,” or “P Tires” selection will change the limit specifications for Road Force® and rim runout.

 The load roller cannot be enabled in “Bare Rim Spin” mode.

To change Road Force® limits touch the Road Force® button. (Figure 210.)



Figure 201.

Touch the “Change Limits Type” button. (Figure 211.)

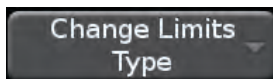

Figure 202.

Touch the type of limits to use. (Figure 212.)

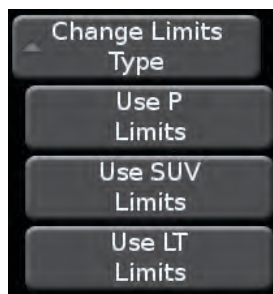



Figure 203.

4.2 Forcematching®

Forcematching® is a method of aligning the stiffest spot of the radial tire road force first harmonic (once-per-revolution component) with the average low point of the radial rim runout first harmonic to decrease vibration in the wheel assembly. This type of match mounting has been done with expensive equipment by the tire/wheel manufacturers and OEMs for years to provide the smooth ride associated with a new vehicle. The Road Force® Elite GSP9700 provides “Forcematching®” at a service level.

When the Road Force® Elite GSP9700 performs a spin with the load roller enabled, it measures the road force of the wheel assembly. ForceMatch® is enabled on every Road Force® spin.

 It is important that the air pressure of the tire is set to specifications prior to using the Road Force Measurement® system. Incorrect tire pressure will affect the results.

ForceMatch® - Display of Data



Figure 204.

After the assembly has been spun, the ForceMatch data will display on screen.

The upper left corner of the screen displays Road Force® and runout data. A 3D display of the assembly is shown, with corresponding “chalk marks” on both the tire and rim. Matching the chalk marks will produce the minimum available Road Force® in the assembly. (Figure 214.)



Figure 205.

Buttons on the right allow the operator to return to the main balance screen, view details and plots, and change the data being viewed.

Touching “Show After ForceMatching” will change the 3D scene (matching up the chalk marks and showing the resulting Road Force® change in the color spectrum on the tire) as well as show the predicted resultant assembly force and diagnosis (upper left data).

Forcematching® - No Runout

If the operator accesses Forcematching® without the required data having been measured, the screen will show the following prompt. (Figure 215.)



Figure 206.

In the event that runout cannot be measured, ensure there is no blockage preventing the inside camera from profiling the wheel. If no blockage has occurred and the machine will not profile a wheel, service may be needed. To forcematch a wheel with no runout measurement, a manual entry is required followed by a 180 match. (see 180 matching below.)

Forcematching® - Show After Prediction

Touching the “Show After ForceMatching” button will change the 3D scene (matching up the chalk marks and showing the resulting Road Force® change in the color spectrum on the tire) as well as show the predicted resultant assembly force and diagnosis (upper left data). (Figure 216.)



Figure 207.

ForceMatch® Procedures

To correct road force by using ForceMatch®:

Rotate the tire Road Force® high spot on the wheel to TDC, or with the hood in the raised position and the servo enabled, touch “START.” Mark the tire with a piece of chalk or a marker at TDC.

Rotate the rim low spot on the wheel to TDC, or with the hood in the raised position and the servo enabled, touch “START.” Mark the rim with a piece of chalk or a marker at TDC.

Use a tire changer and align the tire and rim marks to one another. Refer to the operation instructions for the tire changer in your shop. (Figure 217.)



Figure 208.



If the wheel assembly can be corrected by Forcematching®, the results can be viewed prior to removing the assembly from the balancer by touching “Show After Forcematching”.

If the wheel assembly cannot be corrected by Forcematching®, the diagnosis box will display “Forcematching will not bring assembly within limits” and may suggest component replacement.

Touching the “?” button will display detailed information about the procedure. (Figure 218.) and (Figure 219.)

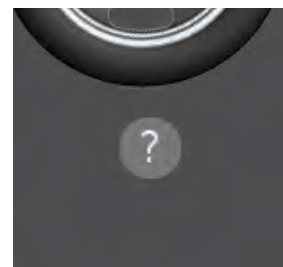

Figure 209.



Figure 210.

Match Codes

Match codes can be used to obtain optimal ForceMatch® results between multiple tire and rim assemblies. They are especially helpful when high Road Force® values are encountered. The former Hunter MatchMaker® feature used a similar system.

When a tire and rim assembly are balanced using ForceMatch®, a number (match code) is displayed above the tire. This is the value of the high spot on the tire. It is an arbitrary number. The below match code is 12. (Figure 220.)



Figure 211.

When the tire and rim assembly is rotated to the low spot on the rim, a number (match code) is displayed above the tire. This is the value of the low spot on the rim. It is an arbitrary number. The below match code is 4. (Figure 221.)



Figure 212.

Use a tire changer and align the tire and rim marks to one another as performed in the standard ForceMatch® procedure.

By matching the highest tire match code value with the highest rim match code value, the Road Force® values can be reduced in a set of two or more tire and rim assemblies.

The below diagram shows a set of four tires and rims and the best use of match codes to reduce Road Force® values. (Figure 222.)

Match Code Values

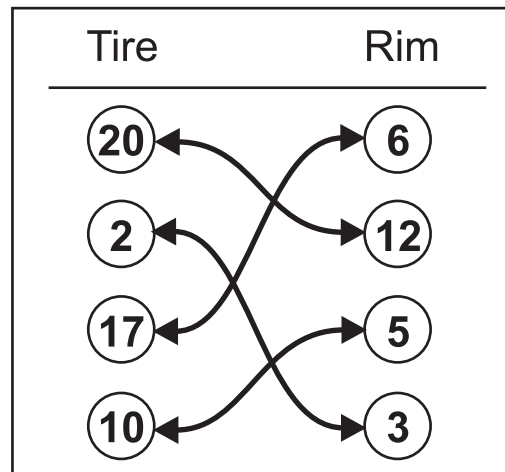

Figure 213.

A routine practice of marking the match code values on the tires and rims when using Forcematching® can reduce the overall time needed to perform optimal ForceMatch® results.

180 Matching

180 Matching will minimize Road Force® in the tire and wheel assembly. It requires a tire changer, as the tire will be repositioned about the wheel during the procedure.

The 180 Matching procedure can be launched by touching the Road Force® button. (Figure 223.)



Figure 214.

Touch the "Procedures" button. (Figure 224.)

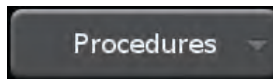

Figure 215.

Touch the "180 Matching" button. (Figure 225.)

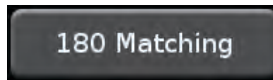

Figure 216.

The progress bar at the top of the screen indicates to the operator how far along the procedure has progressed.

Mount the assembly on the balancer. Set the tire pressure to the vehicle manufacturer's specification. Lower the hood to start the Road Force® measurement. (Figure 226.)



Figure 217.

Position the valve stem at 12:00 and touch "Enter Valve Stem". (Figure 227.)



Figure 218.

Mark the tire with a piece of chalk or a marker with a "V" opposite the valve stem as indicated. Touch "OK" or tap the foot pedal when completed. (Figure 228.)



Figure 219.

Use a tire changer and rotate the rim 180 degrees relative to the tire, aligning the "V" mark with the valve stem. Mount the assembly on the balancer. Position valve stem at 12:00 and press "Enter Valve Stem". (Figure 229.)



Figure 220.

Lower the hood to start the Road Force® measurement. (Figure 230.)

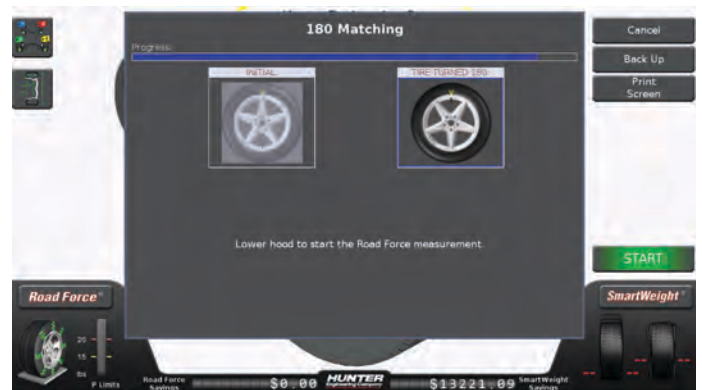

Figure 221.

Encountering Forcematch® Prediction Errors

Below are some reasons why the Road Force® Elite GSP9700 may not match or quantify the value of the tire or the assembly.

- **Incorrect Mechanical Wheel Mounting on the Shaft:**

This can be caused from worn or damaged adaptors, rust or debris on the wheel, shaft, hub, adaptors, or a cone contacting a wheel on an irregular surface. Verify proper mounting by performing a centering check.

- **External Rim Measurement vs. Actual Bead Seat Measurement:**

There is a high correlation between external and internal measurement, however the operator must consider each wheel design individually. Some cast or closed-faced wheels cannot be accurately measured externally. The tire must be removed for accurate bead seat runout measurements.

- **Air Pressure Readings Before and After Matching Differ:**

The air pressure should remain constant between each measurement. Always inflate tires to the recommended pressure specified by the vehicle manufacturer.

- **Incorrect Tire Bead Seating Procedures:**

Tire technology is always changing. Today's vehicles require the tire to be designed to tightly adhere to the wheel, preventing slippage between the two components. As a result, incorrect tire bead seating procedures are becoming more of an issue in solving vibration complaints. In many cases, a wheel will display high non-uniformity values because of increased tire bead interference, wheel design, or improper bead seating procedures. If the tire is re-loosened from the wheel and properly lubricated and remounted, the level of non-uniformity may decrease dramatically. On sensitive vehicles, sometimes there is benefit to slightly over-inflating the tire, deflating the air, and then re-inflating to optimize bead seating.

- **Insufficient Use of Tire Mounting Lube During Mounting:**

"Lube is Good!" Proper lubrication on the tire bead and rim areas including bead seat, hump, balcony, and drop center are vital in achieving proper seating of the tire bead to the wheel assembly. Aggressive acceleration or braking should be avoided for the first 500 miles to prevent tire to wheel slippage.

- **Rim Safety Hump Design 'Hangs Up' Tire Bead During Bead Seating:**

Some types of wheels use a square safety hump that may further inhibit uniform tire bead seating. This further underscores the importance of proper lubrication and bead seating procedures.

- **Temporary Flat Spotting:**

Flat spotting may occur when the tire is in one position for an extended period of time, such as a parked vehicle, improper storage of the tire, and temperature extremes. Measurements for force and balance will stabilize as soon as the tire is driven

for a few miles. This important issue can also affect traditional wheel balancing procedures.

- **Excessive Lateral Runout of Tire and/or Rim:**

A tire or wheel with high lateral readings may affect the predicted results of radial force after Forcematching®.

Do's and Don'ts of Road Force® Measurement

- Tires may need to be warmed up to remove temporary flat spots prior to testing.
- Tire inflation pressure must meet vehicle manufacturers specifications.
- Verify the wheel is centered.
- Use the approved adaptors for the Road Force® Elite GSP9700. Use approved wing nut provided and tighten with two hands to ensure full clamping force.
- The tire/wheel assembly must be free of debris.
- Bare rim runout measurements are required if the wheel design does not permit external measurement of the outer bead seat area.
- Use realistic Road Force® measurement limits for the vehicle being tested.
- If chosen limits have been exceeded, never use Road Force® measurement alone to replace a tire unless specified by the manufacturer.

4.3 StraightTrak® LFM (Lateral Force Measurement)

StraightTrak® is an optional feature that corrects vehicle pull problems by suggesting that the tires be placed at specific locations on the vehicle. If the vehicle being tested has unidirectional tires, or different size tires front and rear, not all of the displayed options will be valid.

Tire-related pulls are caused by lateral forces in the tires. Lateral force is the amount of left or right pull force created as the tire rolls along the road. This condition may cause a vehicle to steer away from straight ahead. These forces are primarily created by conicity and cannot be detected during standard balancing or alignment service.

The StraightTrak® LFM feature measures lateral tire force during the Road Force® Elite GSP9700's "Road Force Measurement®" test. The Road Force® Elite GSP9700 then applies this lateral force information to a set of tires, providing the operator with multiple placement choices about the vehicle. Tires are tagged and positioned on the vehicle to provide the least amount of vehicle pull and obtain the best straight ahead steering stability. Pull or drift caused by the lateral forces can be systematically minimized, offset or eliminated.

Performing a StraightTrak® LFM Procedure:

Mount the tire/wheel assembly centered on the shaft of the Road Force® Elite GSP9700. Use care to make sure the wing nut is well tightened.

Choose the appropriate balancing procedure for the particular type of rim construction.

Check the tire pressure. Inflation Station will automatically inflate or deflate the tire to the preset air pressure. When the tire pressure is correct, the tire graphic on the screen will turn green. (Figure 231.)



Figure 222.



Lateral force varies significantly with tire inflation pressure. For accurate results, it is important that the inflation pressure for each tire is set to the correct value.

Enter rim dimensions by performing a spin.

Press the green "START" button if "Hood Autostart" is disabled.

After the radial measurements are taken, a lateral force sensor measures forces exerted in the lateral (axial) direction. The drive system then reverses direction and again measures the forces exerted in the lateral (axial) direction.

After wheel comes to a complete stop, raise the safety hood.



If Auto Hood is enabled, the hood will raise automatically.

Perform any tire/wheel Force Matching® required to reduce radial Road Force® disturbances.

Apply the appropriate balance weight.

Touch the "Tire Stacking" tab button. (Figure 232.)



Figure 223.

The screen will show the first wheel spun and automatically assign tag 1 to the assembly. (Figure 233.)



Figure 224.

Attach the corresponding identifying tag to the valve stem of the tire/wheel assembly or number the assembly with a tire crayon.

The “Tire Stacking” tab can be opened or closed when performing the procedure. The Road Force® Elite GSP9700 will continue to automatically number the spun assemblies.

Touching the “Tire Stacking” tab button again will close the “Tire Stacking” tab window but automatic numbering will continue.

Mount the second tire/wheel assembly on the Road Force® Elite GSP9700 and perform Forcematching® (if needed) and balancing.

The screen will show the second wheel spun and automatically assign tag 2 to the assembly. (Figure 234.)



Figure 225.

The vehicle plan view will show the net tire pull (if any) for the two measured tire/wheel assemblies.

Mount the third tire/wheel assembly on the Road Force® Elite GSP9700 and perform Forcematching® (if needed) and balancing.

The screen will show the third wheel spun and automatically assign tag 3 to the assembly. (Figure 235.)



Figure 226.

After tagging the third tire/wheel assembly, the vehicle plan view will show suggested placement of the tire/wheel assemblies so that the net lateral force, produced by tire conicity, exerted on the steer axle of the vehicle is minimized. (Figure 236.)



Figure 227.

Mount the fourth tire/wheel assembly on the Road Force® Elite GSP9700 (if needed) and balancing.

The screen will show the fourth wheel spun and automatically assign tag 4 to the assembly. (Figure 237.)



Figure 228.

After tagging the fourth tire/wheel assembly, the vehicle plan view will show suggested placement of the tire/wheel assemblies so that the net lateral force, produced by tire conicity, exerted on the steer axle of the vehicle is minimized.

It will also show net pull (if any). Various choices of tire placement may be chosen to optimize the vehicle for least pull and/or least vibration.

Touch the buttons on the right to cycle through various options showing or hiding “Road Force®”, “Show

Least Pull”, “Show Least Vibration” and “Print” results. (Figure 238.)



Figure 229.

Disabling StraightTrak®

Any instance when lateral force is not an issue (such as when measuring single assemblies), StraightTrak® can be turned “OFF” to reduce cycle time. StraightTrak® can be disabled by touching the load roller on the screen until the StraightTrak® logo is no longer visible. (Figure 239.)



Figure 230.

Vehicle Plan View

The vehicle plan view provides a graphic depiction of the information that is gathered by the Road Force® Elite GSP9700 during a loaded spin.

Touching the “Tire Stacking” tab button shows the vehicle plan view in a simplified form. It shows only the net pull on the assembly after having spun four assemblies. (Figure 240.)



Figure 231.

The vehicle plan can be expanded to show individual Road Force® measurements, individual lateral force measurements, assembly diameters and other pieces of information about measured assemblies. (Figure 241.)

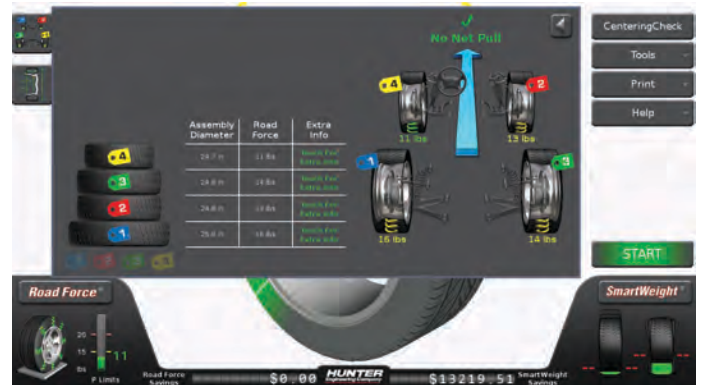

Figure 232.

To access this expanded plan view, touch the arrow button at the top right of the plan view. (Figure 242.)



Figure 233.

To return to the simple plan view, touch the arrow button again. (Figure 243.)



Figure 234.

Net Tire Pull

Net pull indicates the direction and the magnitude of pull, due to the tires, that the vehicle will be subject to, if the tire/wheel assemblies are mounted on the vehicle as currently shown on the screen. Direction will be to the right, or to the left, indicated by an arrow. Magnitude is measured in pounds (lbs) or Newtons (N) and is further indicated by the directional arrow. (Figure 244.)



Figure 235.

Changing Tag Numbers

While on a vehicle plan view screen, touching and “dragging” tags will show the effects of changing assembly locations. (Figure 245.), (Figure 246.) and (Figure 247.)



Figure 236.



Figure 237.

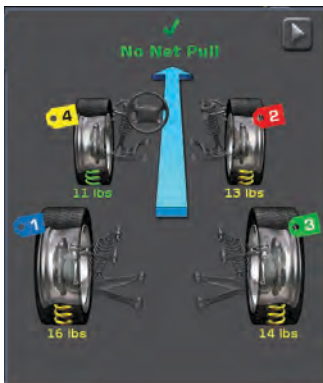

Figure 238.

When the first tire/wheel assembly is ready to be tagged, the only option will be to tag it as tag 1. The second tire/wheel assembly will default to tag 2, however you may change it to tag 1 dragging and dropping the tag to the second location. The third and fourth tire/wheel assemblies may be tagged by accepting the default (the next sequential tag).

Forcing a Tire Onto the Tire Stack

In some cases, it may be desirable to “force” a tire to the tire stack even though it has not been balanced.

Touch the chassis tab.

Observe the current tire stack. (Figure 248.)



Figure 239.

i In this example, no wheels have been balanced or previous data has been cleared.

Locate weight locations / input rim dimensions by performing a balance spin. (Figure 249.)



Figure 240.

i Wheel has been balance spun but no weights have been applied.

Touch the chassis tab.

A semi-transparent tire appears on the stack.



Figure 241.



Since this wheel has not been balanced, a “Not Balanced” icon appears on the left edge of the semi-transparent tire.

Touch the “Save to Tire Stack” button.

The tire is now solid but the “Not Balanced” icon indicates that no corrective weights have been applied.



Figure 242.

Road Force®

Touching the “Hide Road Force” button will turn off the Road Force® listings for all assemblies. (Figure 252.)

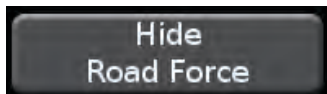

Figure 243.

Touching the “Show Road Force” button will turn Road Force® listings back on. (Figure 253.)

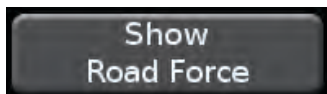

Figure 244.

Road Force® indicates the amount of vertical (radial) Road Force® variation remaining in the tire/wheel assembly after Forcematching®.

Magnitude is measured in pounds (lbs), Newtons (N), or kilograms (kg). To minimize vibration, the tire/wheel assembly with the largest amount of Road Force® is typically positioned farthest away from the driver (right rear). Even though the front (steer) axle tires may be switched to change the direction of net pull, the rear tire/wheel assembly with the largest amount of Road Force® will still be positioned farthest away from the driver.

Show Least Pull

Touching the “Show Least Pull” button will rearrange the tags to show the least pull. (Figure 254.)

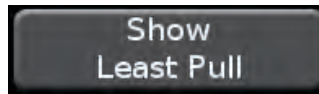

Figure 245.

By touching “Show Least Pull,” the placement of tire/wheel assemblies on the vehicle that will yield the least net tire pull will be shown. This positioning tries to place the two tire/wheel assemblies on the front axle that have the same amount of pull, but in opposite directions when on the vehicle.

Show Least Vibration

Touching the “Show Least Vibration” button will rearrange the tags to show the least vibration. (Figure 255.)

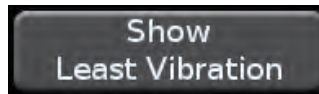

Figure 246.

By touching “Show Least Vibration,” the placement of tire/wheel assemblies on the vehicle that will yield the least vibration will be shown. This positioning will place the tire/wheel assembly with the greatest amount of Road Force® on the passenger side of the rear axle (farthest from the driver). The tire/wheel assembly with the second highest Road Force® will be placed on the driver’s side of the rear axle, and the tire/wheel assembly with the lowest Road Force® will be placed on the driver’s side of the front axle.

Printout

Touching the “Print” button will allow the operator to print summary information. (Figure 256.)



Figure 247.

By printing the summary, the operator has a printed reminder of where to position each tire/wheel assembly on the vehicle to minimize the effects of lateral force. If the desired results are not evident during a test drive, the operator may refer to the alternate placements shown on the printout, without the need to repeat the entire procedure.

The printout can be used to explain the effects of lateral force and the steps taken to reduce their adverse effect to the customer.

Touching the “Vehicle Summary” button opens the Vehicle Summary screen. (Figure 257.)

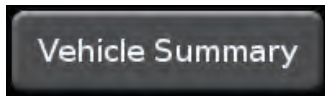

Figure 248.

Custom vehicle summaries can be created by selecting the items to include in the printout. (Figure 258.)



Figure 249.

When a custom summary is created, it can be saved by touching the "Save This Option Set" button. (Figure 259.)

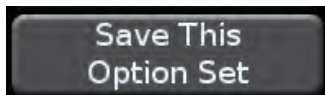

Figure 250.

Custom vehicle summaries can be recalled by touching the "Recall Next Option Set" button. (Figure 260.)

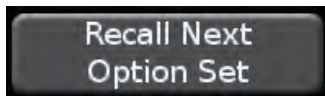

Figure 251.

Print information can also be entered in the text boxes on the Vehicle Summary screen. (Figure 261.)

Use "Header:" to display shop name, address, and phone, or any custom message to appear on the printout.

Use "Name:" to display the customers name.

Use "Vehicle:" to display the vehicle being serviced.

Use "Mileage:" to display the vehicle mileage.

Use "VIN:" to display the vehicle identification number.

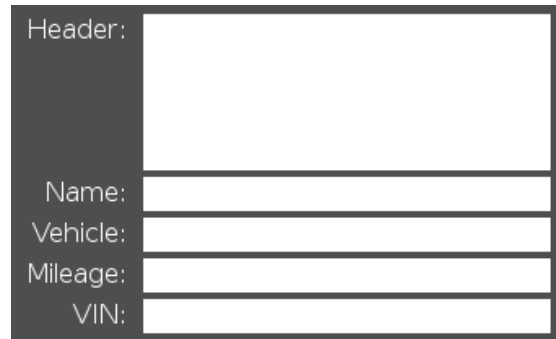

Figure 252.

Touching in any text field will launch the on-screen keyboard. Use the on-screen keyboard to type in the desired fields. (Figure 262.)



Figure 253.

Inflation Pressure

Inflation pressure of each tire, as recorded by the Inflation Station, is displayed on the summary printout. A blank reading indicates that the tire was not measured (inflated or deflated) with the Inflation Station feature.

Summary printout will print the tire pressure rounded to the nearest tenth of a pound. The range allowable to fill each tire may vary on the printout by one or two pounds per assembly. This is considered normal due to the "green bar" tolerance allowable during automatic inflation. (Figure 263.)

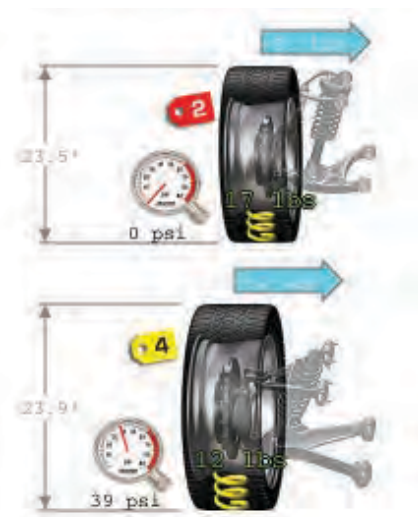

Figure 254.

Extra Info

When viewing the extended plan view, detailed information about each assembly may be viewed by touching “Touch For Extra Info”. (Figure 264.)



Assembly Diameter	Road Force	Extra Info
23.9 in	13 lbs	Touch For Extra Info
23.9 in	13 lbs	Touch To Close
23.9 in	14 lbs	Touch For Extra Info
23.9 in	14 lbs	Touch For Extra Info
23.9 in	13 lbs	Touch For Extra Info

Inner Plane: 0.50oz
Outer Plane: 1.75oz

Time Saved: 04:27:46 AM 02/20/12

Figure 255.

Information such as corrective weight amounts used and individual assembly lateral force will be displayed. Touch “Touch To Close” to close the Extra Info panel.

4.4 Individual Lateral Force Measurement.

Lateral force can be measured on individual tire/wheel assemblies.

The Individual Lateral Force Measurement procedure can be launched by touching the Road Force® button. (Figure 265.)



Figure 256.

Touch the “Procedures” button. (Figure 266.)

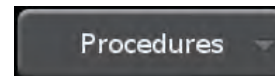

Figure 257.

Touch the “Measure ILF” button. (Figure 267.)



Figure 258.

The progress bar at the top of the screen indicates to the operator how far along the procedure has progressed.

Mount the assembly on the balancer. Set the tire pressure to the vehicle manufacturer’s specification. Lower the hood to start the Road Force® measurement. (Figure 268.)

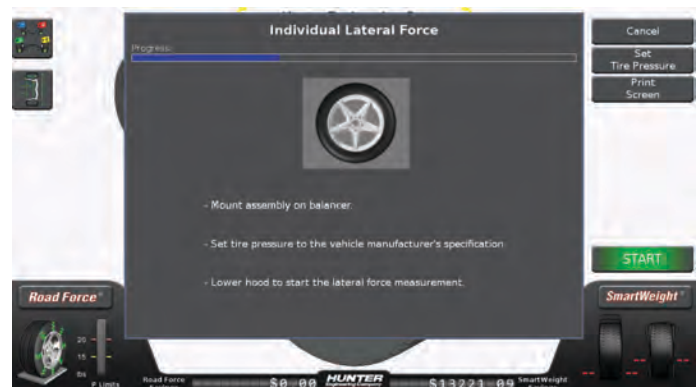

Figure 259.

The first spin will be recorded as spin 1.

Use a tire changer and remove the tire from the wheel. Flip the tire over and remount the tire to the wheel. Set the tire pressure to the vehicle manufacturer’s specification. Mount the assembly on the balancer.

Lower the hood to start the Road Force® measurement.
(Figure 269.)



Figure 260.

The second spin will be recorded as spin 2.

After the assembly is spun, Individual Lateral Force is measured and saved. (Figure 270.)



Figure 261.

Use a tire changer and remove the tire from the wheel. Flip the tire over and remount the tire to the wheel. Set the tire pressure to the vehicle manufacturer's specification. Mount the assembly on the balancer. Touch "OK" to return to the balance screen, then balance the assembly.

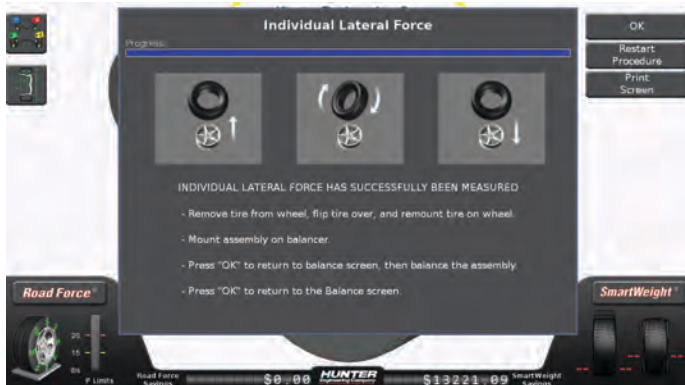

Figure 262.

The Individual Lateral Force measurement results may be viewed by touching the "Tire Stacking" tab button. (Figure 272.)



Figure 263.

To calculate Individual Lateral Force, use the following formula:

$$\text{Net pull} / 2 = \text{Individual Lateral Force}$$

Example: 6 lbs / 2 = 3 lbs Individual Lateral Force.

4.5 Inflation Station

Inflation Station provides preset tire pressure setting to ensure accurate Road Force Measurement® (before and after matching) and safe assemblies for final mounting on the vehicle. Road Force® Elite GSP9700 can reduce as well as increase the tire pressure.

Lift the hose from the storage position (while in the “Balance” or “Runout & Road Force®” screens) and the Inflation Station screen will automatically pop up.

Upon sensing that the air hose is attached to the valve stem, the tire pressure will automatically be set to the target air pressure. The target air pressure is set by the operator, touching the “up” or “down” arrows on the inflation screen. (Figure 273.)

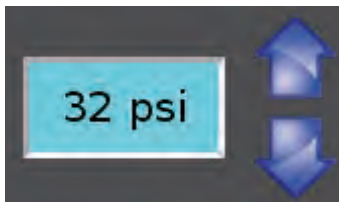

Figure 264.

In cases of a tire with pressure below 15 psi, “Auto-Set Pressure” can be selected to begin filling. (Figure 274.) and (Figure 275.)



Figure 265.

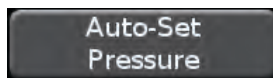

Figure 266.

Touch “Hold Pressure” or “Exit” at any time to halt auto pressure setting. (Figure 276.) and (Figure 277.)



Figure 267.



Figure 268.

When the tire reaches the dialed-in pressure, the on-screen tire graphic will turn green. (Figure 278.)



Figure 269.

The Inflation Station screen exits automatically if the air hose is removed from the valve stem, or if manually exited by touching the “Exit” button.

If the procedure is stopped before completion, an error message will be displayed indicating that target pressure has not been achieved. (Figure 279.)



Figure 270.

For safety, spinning is prevented for the following conditions:

- When the Inflation Station screen is displayed, the hose is not at the storage position
- The hose is pressurized (not disconnected from the valve stem).

4.6 Quick-Thread® Wheel Clamping

Quick-Thread® is an “intelligent” DC drive motor control feature that allows motor assisted threading for fast installation and removal of the Road Force® Elite GSP9700 wing nut.



Keep clear of clamping components during Quick-Thread shaft rotation.

Lift the wheel assembly onto the shaft as normal without threading on the wing nut.

With the left hand, hold the rim over the cone to remove the weight of the rim from the spindle and to allow maximum quick-thread wing nut travel.

Place the wing nut on the spindle and rotate one full turn onto the spindle threads.

With the right hand, hold one handle of the wing nut while lifting the rim.



Heavier wheel assemblies may require extra lifting to prevent the software limited motor torque control from stopping the rotation of the spindle.

Tap the foot pedal twice and the spindle will rotate to install the wing nut to save threading time.

The direction of spindle rotation toggles each time it is used. For normal operation, spindle rotation will begin in the correct direction for wing nut installation. A single tap within the first three seconds of rotation will reverse the direction of rotation. A single tap after the first three seconds of rotation will stop rotation.

Quick-Thread® spindle rotation will stop when the clamping components contact the wheel, or when the foot brake is applied for more than half of a second.



Quick-Thread® does not tighten the wing nut! In Quick-Thread® rotation, torque allowed is minimal. Therefore, the wing nut must still be hand-tightened before balancing.



Because of the software limited torque control, you must loosen the wing nut before Quick-Thread® will remove it.

Quick-Thread® will not operate under the following conditions:

- If the balancer is in “Diagnostics,” “Setup,” or “Calibration.”

SpeedClamp™ Wheel Clamping (Optional)

SpeedClamp™ is an optional spindle equipped with a pneumatic clamping device that eliminates the spin-on type wingnut.

4.7 Motor Drive/Servo-Stop and Spindle-Lok®

Motor Drive/Servo-Stop

The intelligent DC motor drive on the Road Force® Elite GSP9700 is able to position and hold the tire assembly in position for weight application, apply different amounts of torque, and control the speed and direction of the spindle.

When the “Start” button is touched with the hood in the raised position, while weights are showing, the motor will automatically rotate the wheel to the next weight plane and hold the assembly in position for weight or mark application.

Alternatively, touching the weight amounts will achieve the same results.



Figure 271.

Spindle-Lok® Feature

Depressing the foot pedal will lock the spindle. Locking the spindle will stabilize the wheel for attaching weights at precise locations if automatic weight positioning is disabled, and will allow for tightening and loosening of the wing nut.

Do not use the Spindle-Lok® as a brake to stop a spinning wheel.



Depressing the foot pedal will cancel Servo-Stop.



Using the Spindle-Lok® to stop a spinning wheel may result in personal injury or damage to the balancer.

4.8 Safety Hood Features

Hood Autostart

The balancer can be set to automatically spin the wheel upon hood closure. After a spin, the hood must be raised completely before the balancer will Autostart again.

For safety, the balancer will not Autostart in “Calibration,” “Setup,” “Diagnostics,” if no balancing procedure is selected, or if the Inflation Station hose is out of its “home position.”

Auto Hood Feature

The balancer can be set to automatically raise the hood after a spin has been completed.



Keep body parts and items away from the hood while a spin is in progress.





5. Equipment Information

5.1 Tools

The Tools button contains equipment information and set up options.

Set Up

The “Set Up” screen contains a list box of balancer set up items.

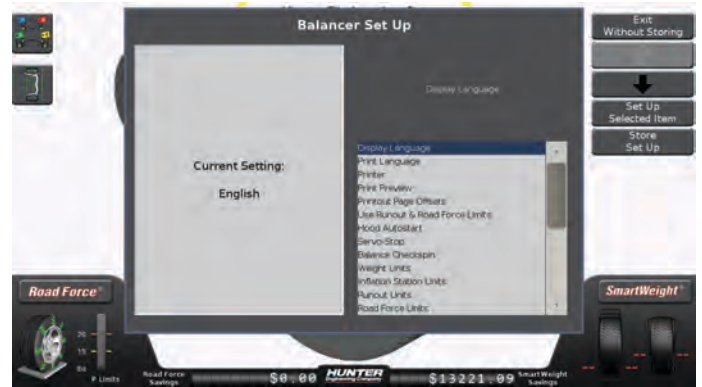

Figure 272.

From the main balance screen, touch the “Tools”, then “Advanced”, then “Set Up” buttons. (Figure 297.)



Figure 273.

Change set up features by touching the desired item then touching the “Set Up Selected Item” button. (Figure 298.) and (Figure 299.)

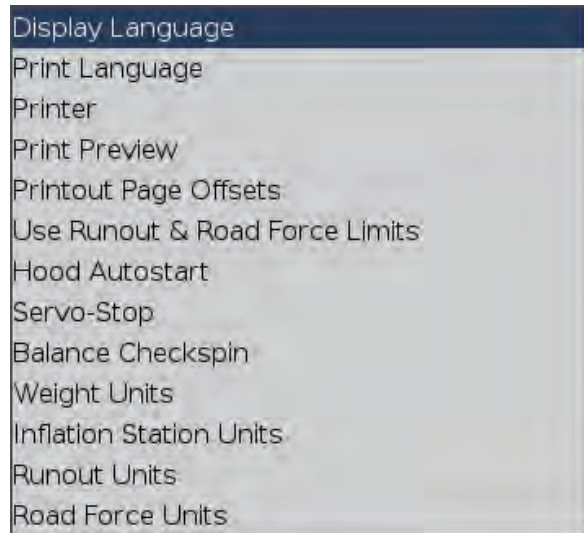

Figure 274.

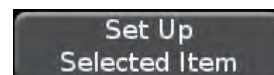

Figure 275.

Available options will be displayed (Figure 300.).

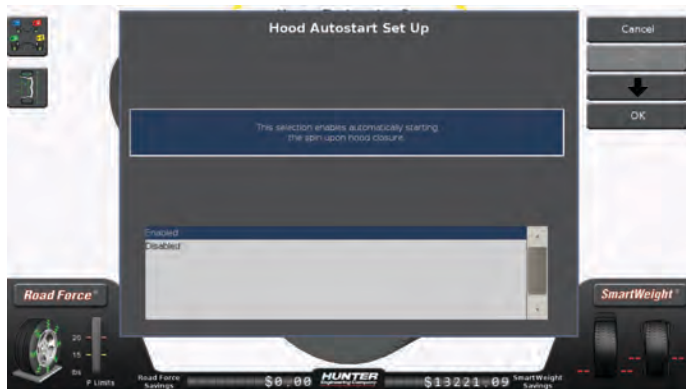

Figure 276.

When the selection is made, touch “OK” to save or “Cancel” to abandon. o scroll up or down in the list of items, either press the “Up” or “Down” arrows, or drag the scroll bar (Figure 301.).



Figure 277.

The upper right area of the set up screen displays the current setting for each feature (Figure 302.).

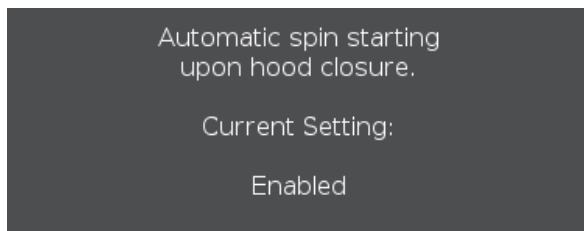

Figure 278.



The set up information is not stored until “Store Set Up” is touched.



Figure 279.

To abandon the set up procedures without saving changes, touch the “Exit” button or reset the system (Figure 304.).



Figure 280.

“Reset All” Button

Clears all data and returns the balancer to a freshly booted condition. (Figure 305.)



Figure 281.

Specification Database

The specification database can be accessed by two different methods.

Touch the specification database tab button or touch the text that says “No Vehicle Selected.” (Figure 306.)



Figure 282.

A drop down list appears listing vehicle makes. Touch the desired make, year and model. (Figure 307.)



Figure 283.



Navigation buttons at the top of the drop down list allow for back and refresh.

Specification information will be displayed. (Figure 308.)



Figure 284.

TPMS specification information can be accessed by touching the “View TPMS Info” button. (Figure 309.)

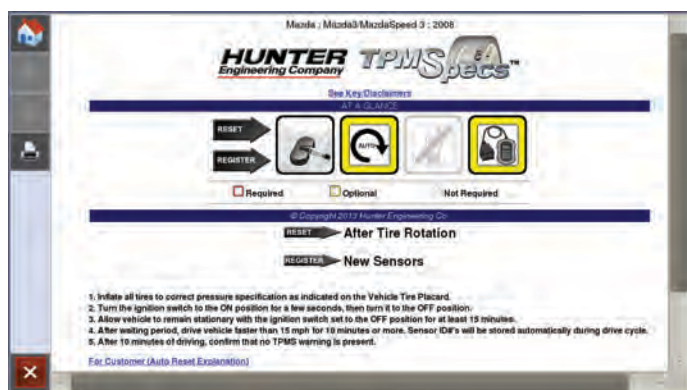

Figure 285.

Figure 286.

The specification database will be updatable.

Display Language

Selects the language for on-screen display.

Print Language

Selects the language for printouts.

Printer

Sets printer output to the desired printer.

Print Preview

Enables or disables print preview.

Printout Paper Size Selection

Selects the size of paper for printouts.

Selectable Print Destination

From any printable screen or report, there is now an option to print to multiple destinations. For example, if there is a printer attached to the balancer and a thumb drive is plugged into a USB port, the operator is given a choice of where the print job should go.

Touch the “print” button. A pop-up dialog box will appear. (Figure 311.)



Figure 287.



When printing to a USB drive, the drive must contain a volume “name”. The USB drive must first be “named” using your laptop or another PC then plug it in an open USB port. Use the one on the neck for easy removal to print on a PC.

Touch the arrow to the right of the listed printer. A list of available destinations will appear.

Select the desired destination and touch “OK”. (Figure 312.)

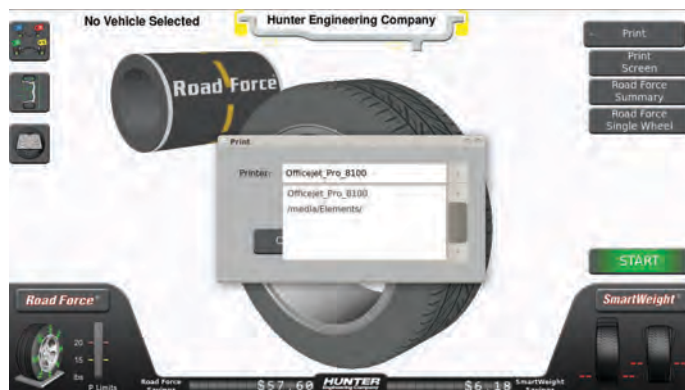

Figure 288.

The same feature is available on customer report print screens. (Figure 313.)

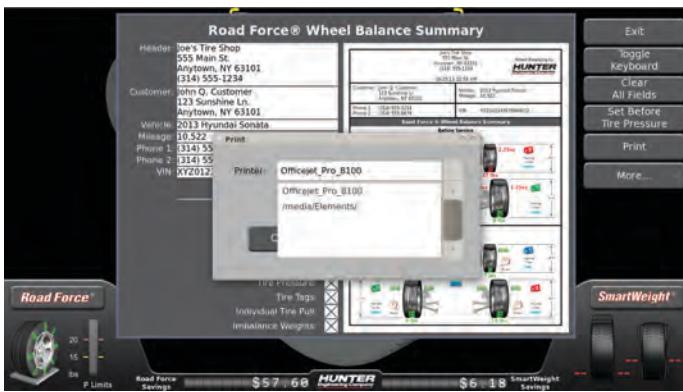

Figure 289.

Use Runout & Road Force® Limits

This set up choice will allow the operator to Road Force® limits. Options are Disabled, Enabled, Enabled with pass/fail limits or Enabled with pass/marginal/fail limits.

Hood Autostart Feature

Enables or disables automatically starting the spin upon closing the hood.

Servo-Stop

Enables or disables the intelligent DC motor drive to automatically rotate the wheel to the weight or ForceMatch® Mark positions. Servo-Push may also be enabled, which allows pushing the wheel (approximately 1/8 of a revolution) to cause the intelligent DC motor drive to automatically rotate the wheel to the next weight or ForceMatch® Mark positions. Touching the “START” key or the weight amounts or locations may still be used for this function. Options are Enabled, Disabled or Enabled with “Servo-Push”

Rim Interior Light

When the hood is lifted after a balance spin, the rim interior light activates. This is useful for inspection, cleaning the rim interior and applying tape weights.

VIN Entry

If the balancer does not have a barcode scanner, VIN's can now be manually entered.

From the main screen, touch the “Tools” button.

Touch the “Manually Enter VIN” button. (Figure 314.)



Figure 290.

Use the on-screen keyboard to type the VIN. (Figure 315.)

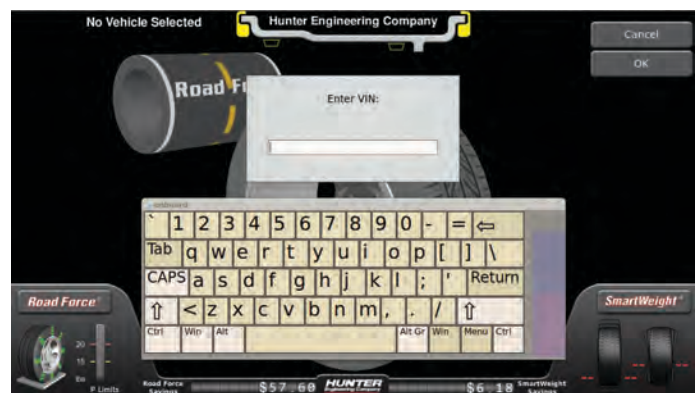

Figure 291.

Touch “OK” to continue.

Balance Checkspin

Enables or disables the load roller during balance verification spins. When enabled the load roller will automatically disabled as necessary. Options are Disabled or Enabled.

Steering Wheel Location in Wheel Assembly Location

Users can choose right-hand drive steering wheel location. This will affect the placement of wheel assemblies on the vehicle for least vibration by correctly locating the wheel with the most vibration furthest away from the steering wheel.

From the chassis tab, touch the “More...” button on the right menu. (Figure 316.)



Figure 292.

i This vehicle is currently set as left hand drive (default).

Touch the “Move Steering Wheel” button. (Figure 317.)



Figure 293.

i The vehicle is now represented as right-hand drive. Tire tags have been moved to produce the least vibration for the right-hand drive vehicle.

Weight Units

Use “Weight Units” to select ounces or grams for displaying wheel weights.

Support of 3M Tape Weights

The ability to use 3M tape weights is now available. Note: the balancer does not have to be in service mode to set up 3M tape weights.

From the main screen, touch the “Tools”, then “Advanced” buttons. (Figure 318.)



Figure 294.

Touch the “Set Up” button. (Figure 319.)

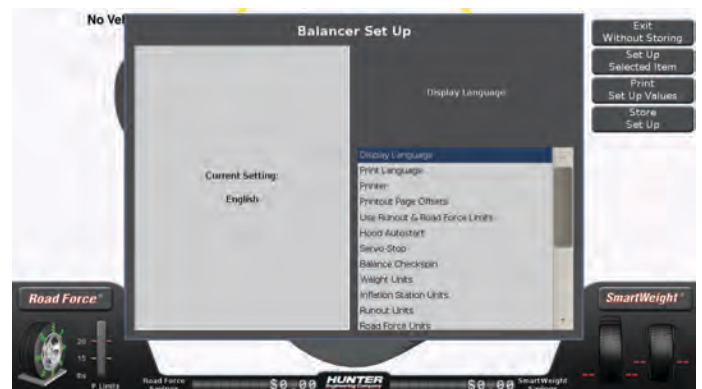

Figure 295.

i The screen will display a list of available set up options.

Scroll down and touch “3M Tape Weights”.

Touch the “Set Up and Selected Item” button. (Figure 320.)



Figure 296.

Touch the boxes that match the size and shape profiles of the 3M tape weights to be used.

Touch "OK" when finished. (Figure 321.)



Figure 297.

Note: If the exact profile of the 3M tape weight(s) to be used is not shown, select the closest match. Physically hold the 3M tape weight(s) up to the screen.

When prompted for adding balance weight, touch the weight icon on the rim. The 3M tape weights will show up as a selection.

Touch the 3M tape weight to use it. (Figure 322.)



Figure 298.

If multiple 3M tape weights are set up, touch the weight that is the closest match to the weight being used. (Figure 323.)



Figure 299.

i Physically hold the 3M tape weight(s) to the screen. The images on the screen are correctly scaled.

Inflation Station Units

Selects psi, bar or kPa units for air pressure, or disable the option altogether.

Runout Units

Selects inches or millimeters for displaying runout measurements.

Load Roller

Enables or disables using the load roller to always be used when balancing.

Road Force® Units

Selects the desired units for road force measurement to be displayed on the screen and in printouts. Select units in pounds, Newtons, or kilograms.

TranzSaver™ Measurement

Enables displaying the assembly diameter on the balance screen. Options are Disabled, Display assembly diameter on balance screen, Display assembly circumference on balance screen, Display assembly revolutions per mile on balance screen or Display assembly revolutions per kilometer on balance screen.

TranzSaver™ Implementation

Mismatched wheel diameter shown on chassis screen.

If 4 consecutively stacked tires show a deviation in diameter, the operator is notified and corrective action can be taken.

When a deviation in wheel diameter is detected in the tire stack, a red notification icon appears over the chassis tab and a notification appears below the chassis layout. (Figure 324.)



Figure 300.

In this example, tags 1, 2 and 4 are 26.7 inches in diameter. Tag 3 is 27.4 inches in diameter. TransSaver™ has identified the deviation.

By dragging 3 to the correct wheel in the stack, the TransSaver™ notifications are dismissed and proper wheel placement can proceed.

Clear Tire Stack

The ability to clear previously serviced wheels from the tire stack is now available.

From the chassis tab, touch the “More...”, then “Clear Data” buttons on the right menu. (Figure 332.)

A warning screen will be displayed stating that all other data will be lost.

Touch “OK” to continue. (Figure 325.)



Figure 301.

The tire stack is cleared. (Figure 326.)



Figure 302.

Rim Dimension Manual Entry - Tape/Tape

In the event of an SmartScan™ failure, balancing can still be performed by using a tape measure to manually input rim dimensions.

Press the dimension button on in the upper left-hand portion of the screen.



Figure 303.

Press the Manual Entry button in the upper right-hand portion of the screen.



Figure 304.

Use a tape measure to measure the lengths called out on-screen. Touch each box and enter the appropriate measured dimensions. When finished, press OK to end manual dimension entry.

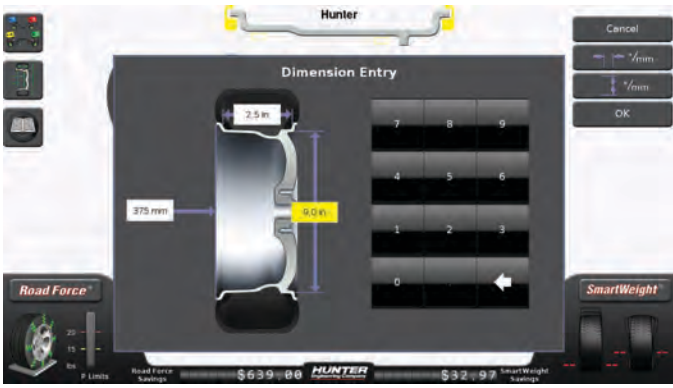

Figure 305.

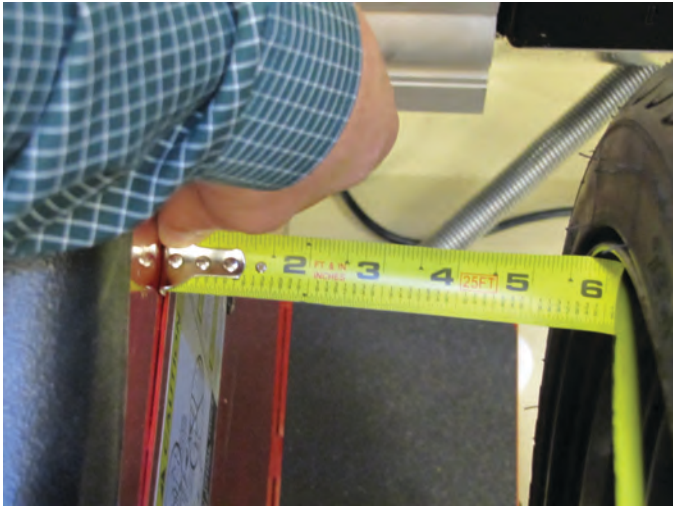

Figure 306.



Figure 307.



Figure 308.

Rim Dimension Manual Entry - Clip/Clip

In the event of an SmartScan™ failure, balancing can still be performed by using a tape measure to manually input rim dimensions.

Press the dimension button on in the upper left-hand portion of the screen.



Figure 309.

Press the Manual Entry button in the upper right-hand portion of the screen.



Figure 310.

Use a tape measure to measure the lengths called out on-screen. Touch each box and enter the appropriate

measured dimensions. When finished, press OK to end manual dimension entry.

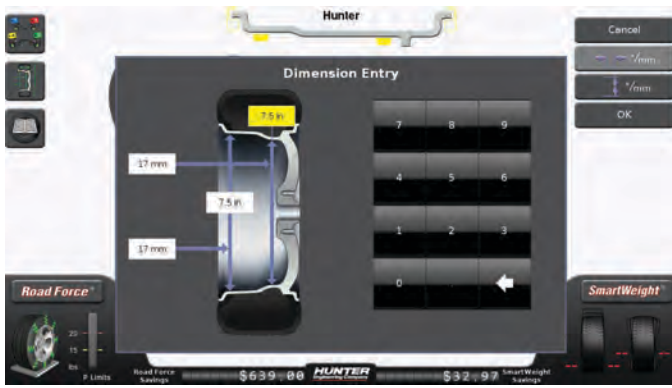

Figure 311.

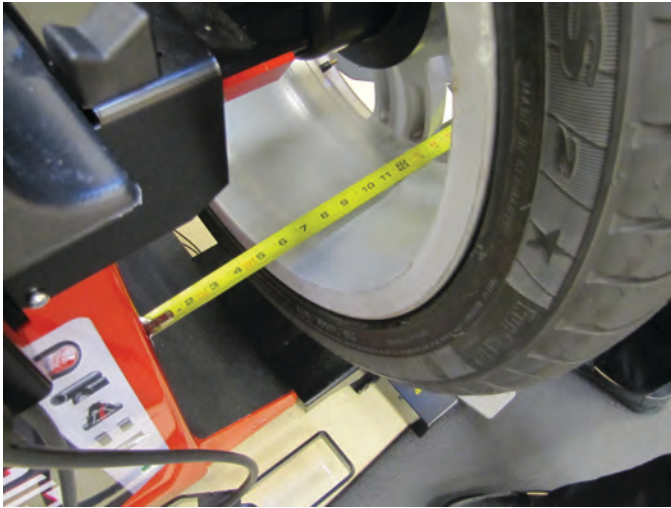

Figure 312.



Figure 313.



Figure 314.

Auto Hood

Automatically opens the hood after a spin. Options are Enabled or Disabled.

Background Color

Changes the background color of all screens.

Volume Control

Selects the volume output for both the beep and click sounds. Video volume is adjustable on the selected video screen. (Figure 339.)

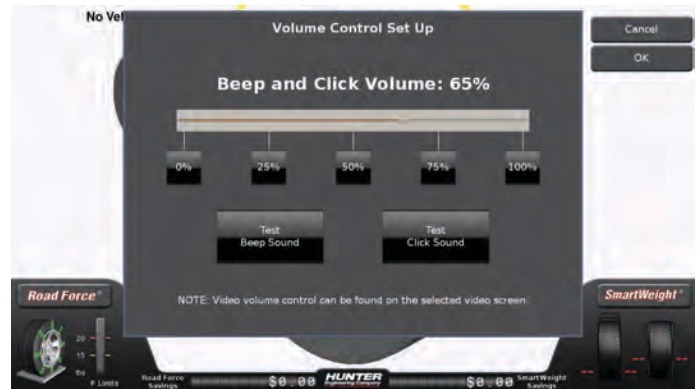

Figure 315.

Date and Time

Date and time can be set by user. There is also support for international date format (DD/MM/YYYY).

From the set up screen, touch "Set Date and Time". Touch the desired time zone.

Touch the desired date and time. Touch the box next to the desired date format. (Figure 340.)



Figure 316.

 To set up a desired time zone, touch “Edit Time Zone”.

Touch the desired time zone. Touch “Set Time Zone” to save.

Wheel Slip Detection

Enables or disables the balancer from giving a warning if wheel slip is detected.

Calibration Procedures

Using calibration procedures, the operator can calibrate the following systems:

- Load Roller

The operator can also perform a 3 Spin Balancer Calibration and check calibration of any of the systems.

From the main balance screen, touch the “Tools”, then “Advanced”, then “Calibration Procedures” buttons. (Figure 341.)

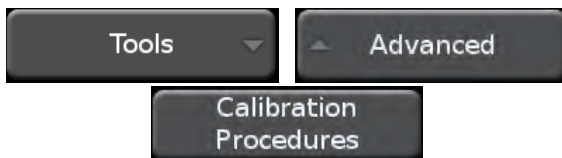

Figure 317.

The main Calibration Procedures screen is displayed. Select the desired calibration procedure and follow the on-screen instructions.

Diagnostics

From the main balance screen, touch the “Tools”, then “Advanced”, then “Diagnostics” buttons. (Figure 342.)

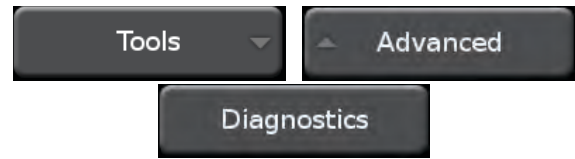

Figure 318.

The main Diagnostics screen is displayed. (Figure 343.)



Figure 319.

Select the desired diagnostic procedure and follow the on-screen instructions. (Figure 344.)



Figure 320.

Identify Software and Authorization

From the main balance screen, touch the “Tools”, then “Advanced”, then “Identify Software” buttons. (Figure 345.)

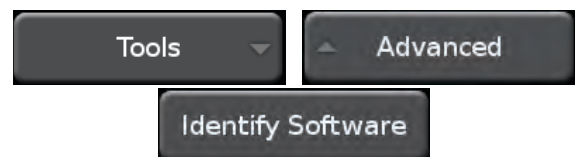

Figure 321.

The Identify Software screen is displayed. (Figure 346.)



Figure 322.

Touch the "Show Authorization" button.(Figure 347.)

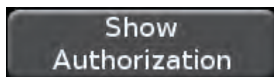

Figure 323.

The Electronic Key Authorization screen is displayed. (Figure 348.)



Figure 324.

Maintenance History

From the main balance screen, touch the "Tools", then "Advanced", then "Maintenance History" button. (Figure 349.)



Figure 325.

The Maintenance screen displays general balancer history. Pressing any of the grey boxes will show a flyout with more information. (Figure 350.)



Figure 326.

TPMS

From the main balance screen, touch the "Tools", then "TPMS" buttons.(Figure 351.)



Figure 327.

The main TPMSpecs® screen is displayed. Select the make, model and specifics of the vehicle being serviced. (Figure 352.), (Figure 353.) and (Figure 354.)



Figure 328.



Figure 329.



Figure 330.

The “AT A GLANCE” overview starts each vehicle TPMS specification. The first image shows the type of TPMS sensor on the vehicle. The following three images show the requirements for servicing the wheel: process, scan tool and OEM scanner. The red border, yellow border or grayed appearance of the image denotes the requirement as required, optional or not required. Red and white striped border indicates the requirement is possibly required; refer to the explanation below the images. (Figure 355.)



Figure 331.

Scroll up or down by dragging the scroll bar, or touching the “up” and “down” arrows on the right side of the screen. (Figure 356.)



Figure 332.

Touch the “Home” button to return to the main TPMSpecs® Menu. Touch the “arrows” to navigate backward or forward. Touch the “print” button to print the current page. Touch “X” to return to the balancer screen. (Figure 357.)



Figure 333.

Clean Threads

From the main balance screen, touch the “Tools”, then “Clean Threads” buttons. (Figure 358.)



Figure 334.

The main Clean Threads Explanation screen is displayed. (Figure 359.)

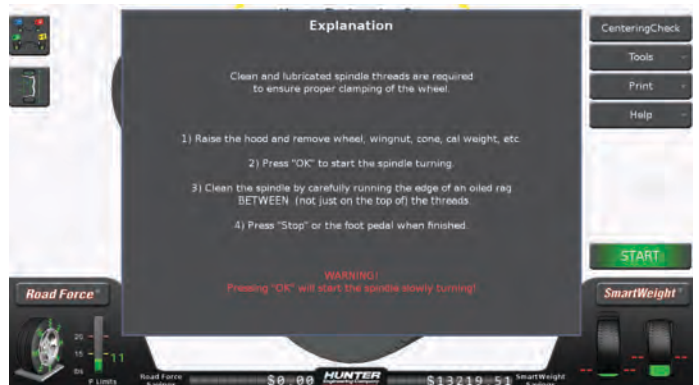

Figure 335.

Follow the on-screen instructions to clean the spindle threads.

After the spindle threads are cleaned, touch the “Exit” button to return to the main balance screen. (Figure 364.)

Balance Bare Rim

From the main balance screen, touch the “Tools”, then “Balance Bare Rim” buttons. (Figure 360.)



Figure 336.

The balance screen is displayed with a bare rim. During bare rim balancing, the load roller is disabled. (Figure 361.)



Figure 337.

Balance the rim as normal, taking dimensions, applying weights, etc. (Figure 362.)



Figure 338.

Touch the “Balance Rim With Tire” button to return to standard balancing. (Figure 363.)

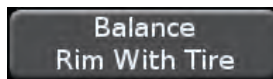

Figure 339.

5.2 USB Program Flash Drive and Security Key Removal and Installation

Turn power to balancer OFF.

Remove the rear cover from the support assembly for the LCD display by removing the six screws. Set the rear cover and attaching hardware aside.

Insert the USB program flash drive(s) into open USB sockets on the Mini-ITX/Atom Motherboard. Verify that the USB drives are fully seated. (Figure 364.)

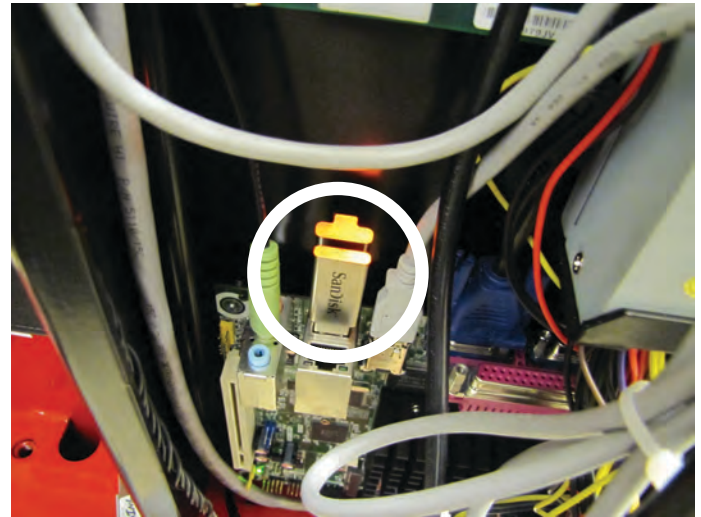

Figure 340.

Remove the weight tray anvil. Set the weight tray, weight tray anvil and attaching hardware aside.

Install the supplied electronic security x-key(s) in the button socket on the board within the tub. (Figure 365.)

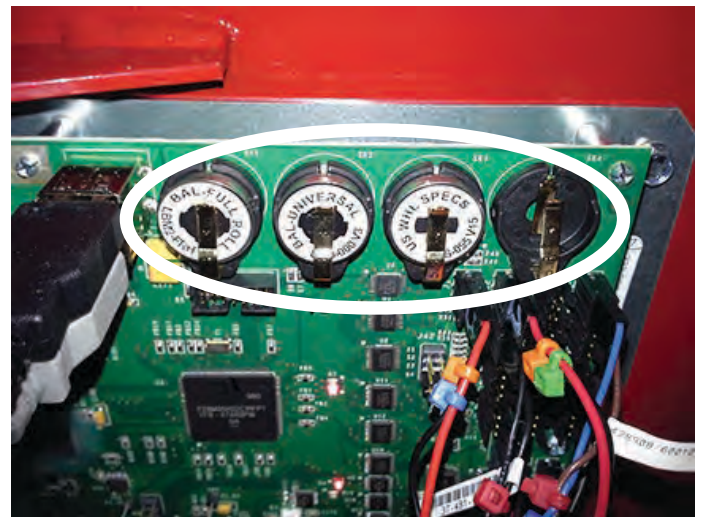

Figure 341.

Re-install the weight tray and rear support cover.



The balancer must be completely re-calibrated after program cartridge installation.

THIS PAGE INTENTIONALLY LEFT BLANK

6. Calibration and Maintenance

6.1 Calibration Procedures

eCal™ Auto-Calibration

The Road Force® Elite GSP9700 utilizes eCal™ automatic calibration. Once the balancer is calibrated at installation time, no further operator input is required.

Calibration Procedures

Using calibration procedures, the operator can calibrate the following systems:

- Load Roller

The operator can also perform a 3 Spin Balancer Calibration and check calibration of any of the systems.

From the main balance screen, touch the “Tools” button. (Figure 396.)

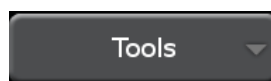

Figure 342.

Touch the “Advanced” button. (Figure 397.)

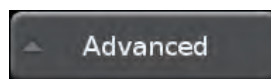

Figure 343.

Touch the “Calibration Procedures” button. (Figure 398.)

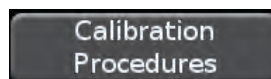

Figure 344.

The main Calibration Procedures screen is displayed. (Figure 399.)

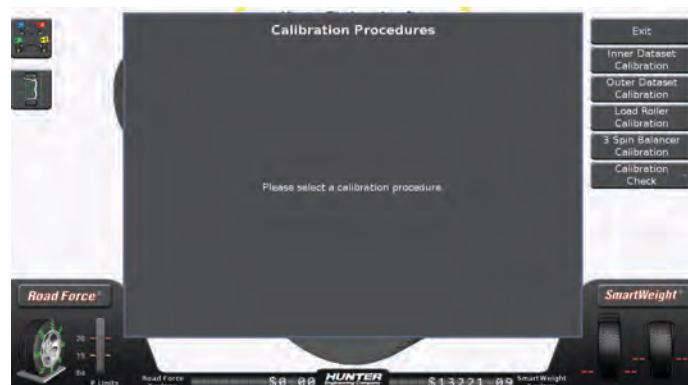

Figure 345.

Select the desired calibration procedure and follow the on-screen instructions.

Calibration Check

A quick calibration check can be performed on the balancer using a calibration weight.

From the main balance screen, touch the “Tools”, then “Quick Calibration Check” buttons. (Figure 400.)



Figure 346.

Touch the “Quick Calibration Check” button. (Figure 401.)



Figure 347.

Screw in the calibration weight and clamp a large cone or collet to the shaft. Lower the hood and press start to begin the check. (Figure 402.)



Figure 348.

Rotate the shaft to the 12:00 position until the yellow dot on the screen turns green to complete the check. (Figure 403.)



Figure 349.

6.2 Diagnostic Tools

The balancer is equipped with a series of self-diagnostic tools. From the main balance screen, touch the “Tools” button. (Figure 404.)



Figure 350.

Touch the “Advanced” button. (Figure 405.)

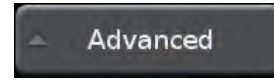

Figure 351.

Touch the “Diagnostics” button. (Figure 406.)



Figure 352.

The main Diagnostics screen is displayed. (Figure 407.)

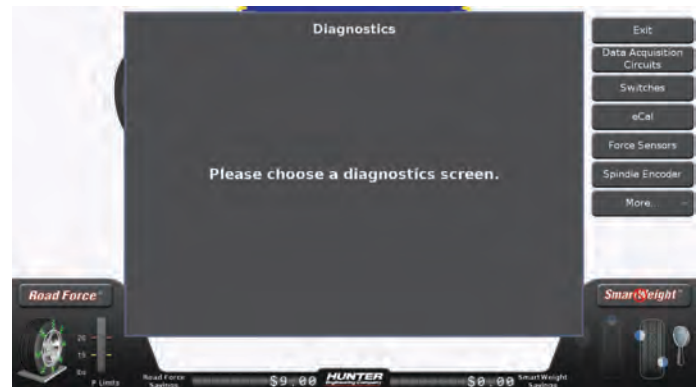

Figure 353.

Most of the diagnostic data is for the sole purpose of conveying information to the Hunter Service Representative. The service representative may request information from these screens to diagnose service concerns. The ability to convey diagnostic data to the representative prior to service expedite repair to the equipment.

Data Acquisition Circuits

Touch the “Diagnostics” button. (Figure 408.)

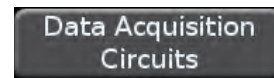

Figure 354.

The Data Acquisition Circuits screen is displayed. (Figure 409.)

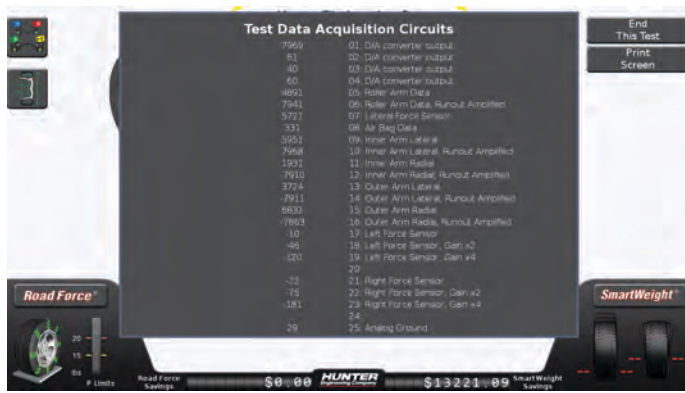

Figure 355.

Switches

Touch the “Switches” button. (Figure 410.)



Figure 356.

The Switches screen is displayed. Follow the on-screen instructions to perform each test. (Figure 411.)



Figure 357.

eCal™

Touch the “eCal” button. (Figure 412.)



Figure 358.

The eCal™ screen is displayed. (Figure 413.)



Figure 359.

Touch the “eCal History” button. (Figure 414.)

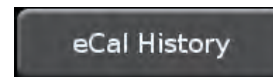

Figure 360.

Choose which eCal history time frame to view. The eCal history is displayed. (Figure 415.)

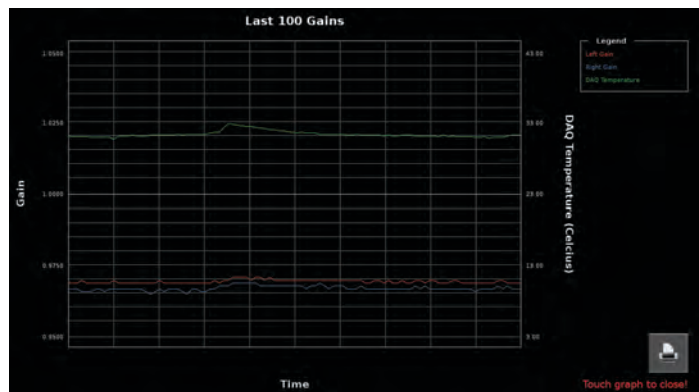

Figure 361.

Force Sensors

Touch the “More...” button. (Figure 416.)

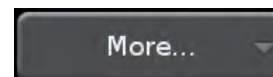

Figure 362.

Touch the “Force Sensors” button. (Figure 417.)

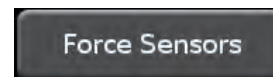

Figure 363.

The Test Force Sensors screen is displayed. (Figure 418.)

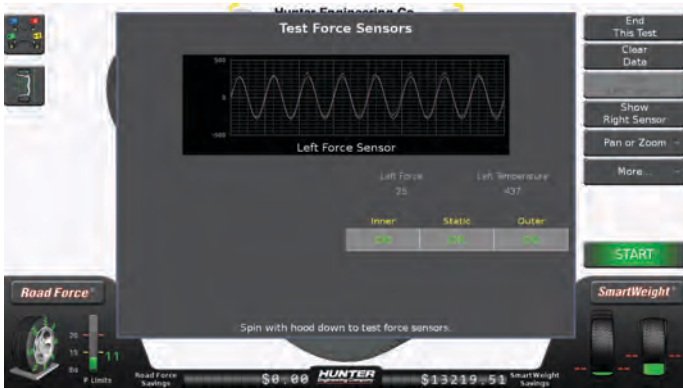

Figure 364.

Spindle Encoder

Touch the “More...” button. (Figure 419.)

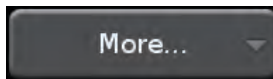

Figure 365.

Touch the “Spindle Encoder” button. (Figure 420.)

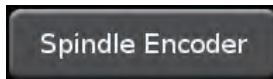

Figure 366.

The Test Spindle Encoder screen is displayed. (Figure 421.)

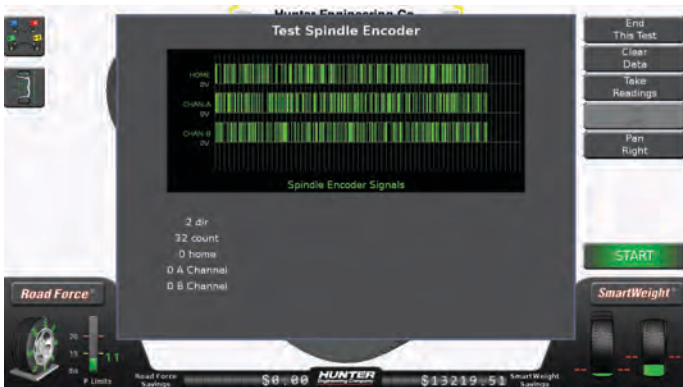

Figure 367.

Loaded Runout Sensor

Touch the “More...” button. (Figure 422.)

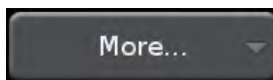

Figure 368.

Touch the “Loaded Runout Sensor” button. (Figure 423.)

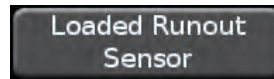

Figure 369.

The Explanation screen is displayed. Follow the on-screen instructions. (Figure 424.)

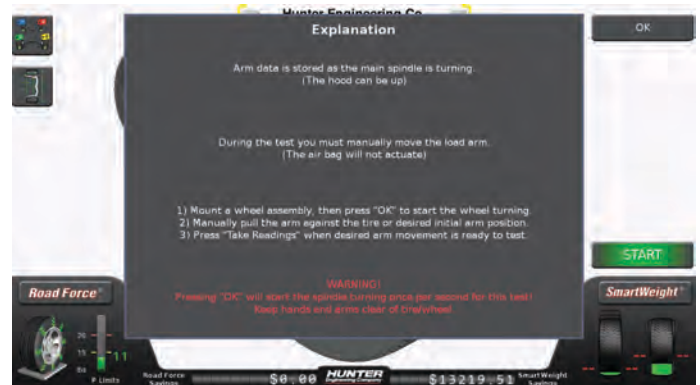

Figure 370.

The Test Loaded Runout Sensor screen is displayed. (Figure 425.)

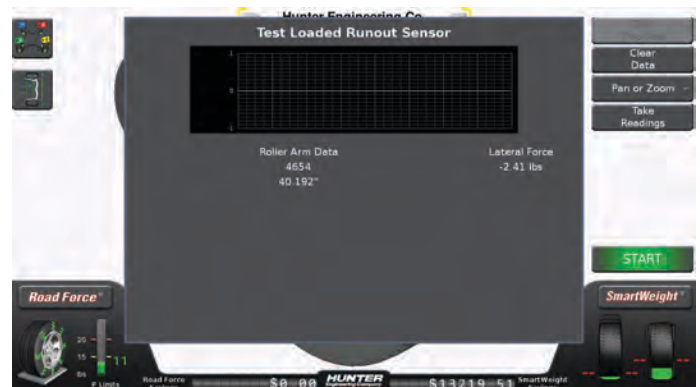

Figure 371.

6.3 Cleaning the Console

When cleaning the console, use window cleaning solution to wipe off the display console and cabinet. Do not spray window cleaning solution directly onto LCD. Power should be "OFF" prior to cleaning the LCD.



Exposing the balancer to water either by hose, bucket, or weather may cause risk of electrical shock to operator or bystanders and will damage the electrical system. Place, store, and operate the balancer only in a dry, sheltered location.

Cleaning the Screen



Do not touch the screen with chemicals or solvents on fingers, i.e. brake cleaner. Doing so will damage the anti-glare protector on the screen.

Safety Instructions

- Please keep the display away from any heat sources such as electric radiators or direct sunlight. Place the display in a stable and well-ventilated place.
- The holes or openings on the display are designed for ventilation. Do not cover or block the ventilation holes or openings with any objects.
- As the display surface is vulnerable to scratches, avoid touching the surface with nail or pen point.
- Shut off the power supply before cleaning. Use a soft lint-free cloth instead of a tissue to wipe the screen.
- You may use a glass cleaner to clean the product as required. However, never spray the cleaner directly onto the display surface.
- Do not attempt to repair this product yourself! Improperly disassembly of the product may expose you to danger! If your problem cannot be solved according to the "Troubleshooting" guidelines, contact your regional HP authorized service provider, <http://www.hp.com/support>.

To maintain a brand new appearance of the display, clean with soft cloth regularly. Please remove stubborn stains with soft cleaner rather than strong cleaners such as diluting agent, benzene or corrosive cleaner as they may damage the display. For the sake of safety, remove the power plug prior to cleaning.

ArmorAll wipes are a suitable cleaning product for the touch screen.

Spindle Hub Face and Shaft

Keep the shaft and wing nut threads clean and lubricated. Lubricate the shaft without contaminating the hub face. Run the edge of a rag between the threads while the spindle is slowly turned by the motor drive. If any signs of dirt or debris appear on the spindle threads, the spindle should be cleaned immediately prior to mounting a wheel.



Caution! Failure to clean spindle properly will result in a loss of clamping force. Due to the force applied to the wheel by the load roller, it is critical to maintain optimum clamping force.

Lubricate the shaft with a coating of light lubricant with Teflon[®] such as Super Lube[®] by Loctite after cleaning. Do not lubricate the spindle hub face mounting surface. This could cause slipping between the wheel and the hub face. Keep the hub face mounting surface clean and dry.

Optical Scan Rim Measurement Maintenance or Service

This Laser Product is designated as a class 1 Laser during all procedures of operation.

Never look directly into the laser. Doing so may cause serious injury.

Do not intentionally use a reflective device to enhance or re-direct the laser.

Do not operate the laser if the cover or seal is damaged.

There is no required maintenance or service to keep the Optical Scan Rim Measurement Laser System in compliance.

The laser is not a field serviceable part or an adjustable part.

Any necessary repair or maintenance should be done by the factory only. The Optical Scan Rim Measurement Laser System has no field serviceable parts.

The unit should never be opened or modified.

Optional HammerHead[®] TDC Laser Clip-On Weight Locator Maintenance or Service



Caution! Use of controls or adjustments or performance of procedures other than those specified herein may result in hazardous radiation exposure.

This Laser Product is designated as Class 2M during all procedures of operation.

Do not stare into the beam or view directly with optical instruments. Doing so may cause serious injury.

Do not intentionally use a reflective device to enhance or re-direct the laser.

Do not operate the laser if the cover or seal is damaged.

There is no required maintenance or service to keep the HammerHead® TDC Laser System in compliance.

The laser is not a field serviceable or an adjustable part.

Any necessary repair or maintenance should be done by the factory only. The HammerHead® TDC Laser System has no field serviceable parts.

The unit should never be opened or modified.

6.4 Mounting Collet Maintenance

Keep the mounting collets clean and lubricated. Lubricate with a coating of light lubricant with Teflon® such as Super Lube® by Loctite.

Do not use collets in any way that is not described in this operation manual. This could cause damage to the mounting collet and not allow for proper mounting of the wheel.

6.5 Maintenance Schedule

Follow schedule to keep balancer performing at its best.

Maintenance Schedule	Perform the following Maintenance
Daily	<ul style="list-style-type: none"> • Spindle Maintenance - Keep the spindle shaft assembly and wing nut threads clean and lubricated. Clean the spindle threads by running the edge of a rag between the threads while turning the spindle by hand. Lubricate the shaft with a coating of light lubricant with Teflon® such as Super Lube® by Loctite after cleaning. Do not lubricate the spindle hub face-mounting surface. This could cause slipping between the wheel and the hub face. Keep the hub face-mounting surface clean and dry. • Cone maintenance - Keep the mounting cones clean and lubricated. Lubricate with a coating of light lubricant such as WD-40. Inspect cones for excess wear, dings, burrs, or other damage that may prohibit proper centering. Do not use cones in any way that is not described in the operation manual. This could cause damage to the mounting cone and not allow for proper mounting of the wheel. • Inspect wingnut and clamp cup for excessive wear or damage. • Cleaning the console - When cleaning the console use the included ArmorAll Glass wipes to wipe off the display console and cabinet. Do not spray any type of cleaning solution directly onto control panel or LCD resistive touch screen. Do not use shop air to clean the display. Power should be off prior to cleaning the LCD resistive touch screen.
Periodically (when balancer chases weight on check spin)	<ul style="list-style-type: none"> • Perform a QuickCal Check to determine if calibration is necessary. This should be performed after balancer has been in operation for at least 10 minutes.
Monthly	<ul style="list-style-type: none"> • Inspect inlet air filter/dryer - clean, replace as necessary
Semi-Annually	<p>Preventative maintenance visit by Hunter Service Representative which will include all the above in addition to the following:</p> <ul style="list-style-type: none"> • Perform audit check (quality report for vibration control system) • Perform full system diagnostics (including air system) • Load roller friction material inspection • Check printer operation • Cone inspection with dial indicator • Check belt tension • Full system calibration



The end user is responsible for replacement of all consumable items such as printer ink cartridges, cleaning wipes, and batteries.



Do not use shop air to clean the LCD resistive touch screen. Shop air could be wet, dirty, or too powerful for the display and can cause problems with the display.

THIS PAGE INTENTIONALLY LEFT BLANK

7.Theory of Operation

7.1 Harmonic Vibrations

A vibration in a tire and rim assembly can be caused by:

Imbalance

Change in Sidewall Stiffness (Force Variation)

Rim Bent/Out-of-Round

Tire Out-of-Round

Wheel to Axle Mounting Error*

Brake Component Wear or Failure*

Drivetrain or Engine Component Wear or Failure*

Vehicle Component Characteristics*

Combination of Some or All Factors

*Factors not detected by the Road Force® Elite GSP9700 Series Road Force Measurement System.

A vibration that occurs one time for every revolution is defined as a first harmonic vibration: (Figure 426.)

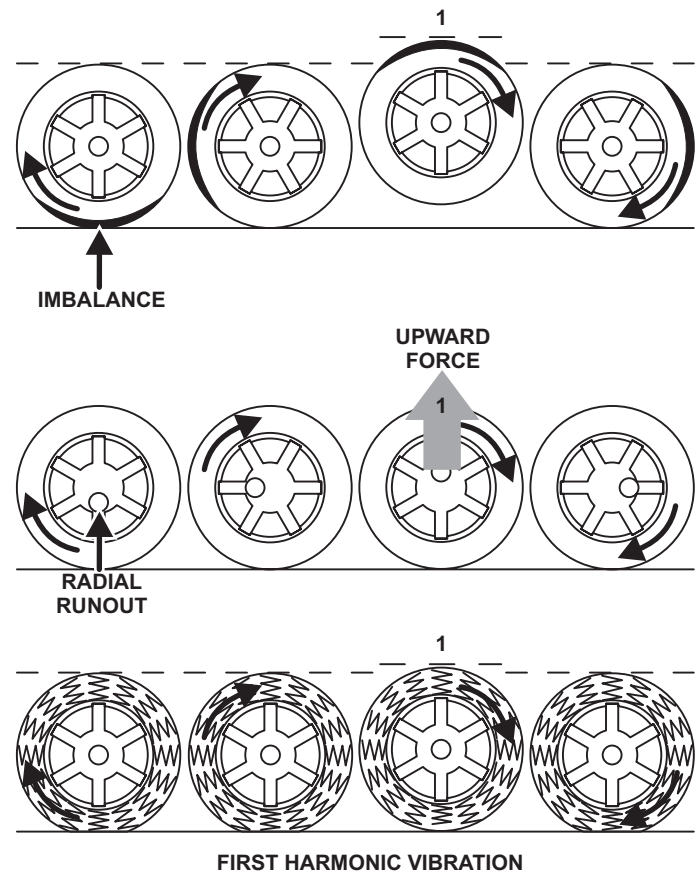

Figure 372.

During Forcematching®, the first harmonic vibration of the tire is matched opposite of the first harmonic vibration of the rim to decrease the first harmonic vibration of the

assembly. This reduces the vibration felt inside of the vehicle.

A vibration that occurs twice for every revolution is defined as a second harmonic vibration. Because there are two vibrations per revolution, the second harmonic vibration occurs at twice the frequency of a first harmonic vibration: (Figure 427.)

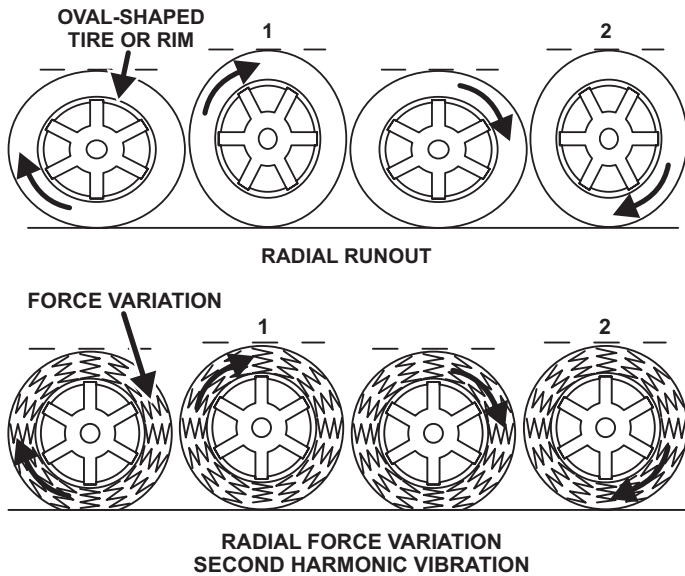

Figure 373.

Multiple harmonic vibrations may also occur. For instance, the third order vibration causes a three times per revolution vibration: (Figure 428.)

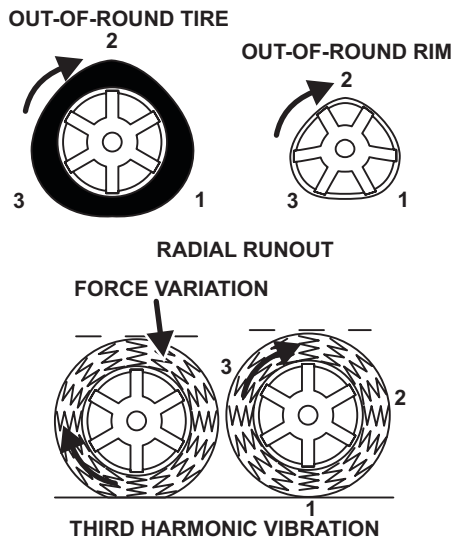

Figure 374.

Multiple harmonic vibrations may occur at any harmonic factor, dependant only upon the number of vibration components in each revolution.

7.2 Road Force® and Runout Measurement

Road Force Measurement® emulates tire uniformity measurement, which has been measured for years in assembly plants and manufacturing facilities. Road Force Measurement® can be used to locate and solve uniformity related tire and wheel vibrations. Tire/wheel assembly uniformity can only be measured under load.

With changes in vehicle sensitivity and increasing ride quality expectations, wheel balancing alone may not be sufficient to eliminate the tire/wheel assembly as a vibration source. The Road Force® Elite GSP9700 Road Force Measurement® System is a measuring and diagnostic tool and automatically detects possible vibration sources in a tire/wheel assembly that cannot be identified by traditional balancing methods. As a diagnostic tool, the Road Force® Elite GSP9700 reduces the unnecessary replacement of tires and wheels, significantly reduces troubleshooting time, and offers improved ride quality.

The load roller on the Road Force® Elite GSP9700 performs a computer simulated “road test.” It measures the tire/wheel assembly to determine how “round” the assembly is when rolling under a load. If a tire were not exposed to the road surface, then balance would be more than sufficient. However, not all tires roll round under a load. For example, an egg-shaped tire/wheel assembly can be balanced about its axis, but an egg-shaped tire/wheel loaded against a surface would not give a smooth ride.

The Road Force® Elite GSP9700 reduces diagnostic time by identifying vibrations that would not be detected by the normal balancing procedure. Road Force Measurement® also detects loaded and free measured runout, force variation of the tire, and balancer mounting error, allowing superior quality balance of the entire wheel assembly.

Road Force Measurement® is a measurement of the wheel assembly as would be found from an actual road test of a vehicle. The Road Force® Elite GSP9700 is equipped with a load roller to take the Road Force Measurement®. The load roller places up to 1400 pounds of force on the spinning tire, and then automatically withdraws from the wheel.

Force Variation

Force variation is a correctable symptom of the tire and/or rim being out of round, the changes in stiffness of the sidewall and footprint of the tire when a load is placed against it, or a combination of both factors acting on the assembly. Force variation can cause a vibration, although the unloaded runout of the tire and rim measure perfectly round and the assembly is balanced.



It is important that the air pressure of the tire is set to specifications prior to the Road Force Measurement®. Incorrect tire pressure will affect the results.

Tire Radial Force Variation (Uniformity)

To understand the effects of radial force variation, imagine the tire as a collection of springs between the rim and the tire tread. If the “springs” are not of uniform stiffness, a varied force is exerted on the axle as the tire rotates and flexes. This creates a vibration in the vehicle. (Figure 429.)

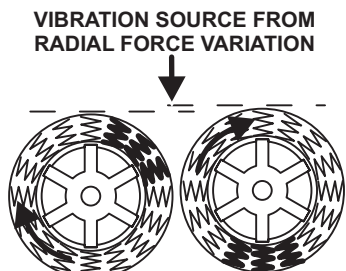

Figure 375.

With the increasing need for low tire uniformity values to minimize vibration complaints, more tire companies are grinding or cutting tires during the manufacturing process. As a result, free runout measurement is no longer an accurate indicator of how the tire assembly will perform when rolling under load. Free run out measurement should not be used as a guide to determine the tires contribution to the ride disturbance complaint.

The Road Force® Elite GSP9700 takes a measurement of the wheel assembly’s radial force variation and displays the results. If the Road Force® Elite GSP9700 perceives a problem with the force variation, it will prompt the operator to measure rim runout. When the rim runout data is entered, the Road Force® Elite GSP9700 extracts and displays the first harmonic force variation contribution of the tire and of the rim. The Road Force® Elite GSP9700 allows the first harmonic of the tire to be matched opposite of the first harmonic of the rim to decrease the first harmonic vibration. The tire and/or rim may need to be replaced or Forcematched® prior to balancing.

7.3 Radial Force Variation (RFV)

Radial force variation is a term describing the direct measurement of the tire uniformity forces under load, measuring the variation (up and down) of the load acting on the vehicle spindle (SAE practice J332).

All tires have some non-uniformity in the sidewall and/or footprint due to variables in the manufacturing process. Tire uniformity measurement values can be affected by rim width, rim condition, and/or tire mounting variables. Unlike balancing, there is often a small amount of RFV remaining in the tire/wheel assembly after ForceMatching® and this is generally acceptable.

What is Road Force Measurement® ?

Road Force® Elite GSP9700 Road Force Measurement® (a roller turning against the tire under high loads) will most accurately locate and quantify the conditions in the wheel/tire that cause non-balancer related vibration and radial tire-pull complaints. The combined effects of geometric (eccentricity) and constructional (hidden internal) related issues can only be measured if a load is placed against the tire. It is the most effective way to quantify the effect of all items in a tire and wheel contributing to non-uniformity of the assembly. Loaded (force) measurement has been the accepted industrial standard used by tire and vehicle manufacturers for over 30 years. (Figure 430.)

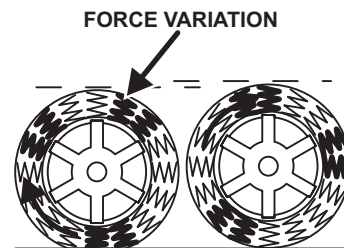

Tire Related Forces are Reveled Only When Testing Under Load

Figure 376.

Road Force Measurement® is displayed in pound force (Lbs.), kilogram force (Kg.) or Newton (N). There are two major components analyzed during Road Force Measurement® that contribute to the total non-uniformity of a tire and wheel assembly: (1) Loaded Runout Measurement and (2) Tire Stiffness Measurement.

Road Force Measurement® uniquely combines loaded runout (eccentricity) measurement of the tire-wheel with the effects of the tire’s overall stiffness. Eccentricity when stated in terms of runout alone does not quantify the actual force because the force is dependent on the stiffness of the tire being measured. Runout does not necessarily create the same force from tire to tire. For example, two tires with the same runout will differ in their ability to create vibration when a stiff tire sidewall is compared to a similar tire with soft sidewall. The stiffness

of the tire will reduce or increase the eccentricity of the assembly when rolling under load.

Runout Measurement is a distance measurement not a force. Runout is traditionally measured in thousandths of inches (0.000") or hundredths of millimeters (0.00mm). Runout can be measured in an unloaded/free state or loaded "road test" condition. Runout measurement of a tire is a compromise compared to calculating forces and is not as effective when diagnosing vibration problems. Runout measurement in a loaded "road test" condition is faster than unloaded runout measurement, however it is not as effective as calculating the Road Force® since the stiffness effect of the tire are not taken into consideration. (Figure 431.)

OUT-OF-ROUND TIRE

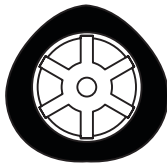

OUT-OF-ROUND RIM

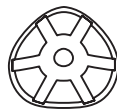

Runout (Eccentricity) is the Only Part of the Vibration Measurement Needed

Figure 377.

Loaded Runout Measurement is performed on a tire with a loaded roller placed against the footprint of the tire. The load roller performs a 'simulated' road test but differs from Road Force Measurement® because tire stiffness is not measured. Loaded runout is the most effective method of runout measurement that samples the entire tire footprint. Measuring the tire footprint with a loaded roller is unlike any form of tread sampling with unloaded runout. The tire under load is tested in a similar manner it is driven on the road. A loaded runout test is a faster than single area sampling and automatically averages the runout of the tire footprint. A tire is compressible and therefore loaded runout measurement is a preferred method over unloaded runout.

Unloaded Runout Measurement is a good choice when measuring a non-compressible object such as a wheel. The best way to measure a wheel is to average the runout of bead seats. Unloaded runout of a tire is the least preferred method to quantify vibration issues. Unloaded runout involves measuring a small area of the tire such as the center rib. Usually the center area of the tire is used because unloaded runout measurement has been proven to be different at various spots across the tread. The problem with center tire measurement is that measuring in the center tread area has the least influence on the actual forces transmitted to the vehicle. It's logical that unloaded runout at the center tread area completely flattens against the road as the tire rolls. This is why unloaded runout is the least preferred method to quantify vibration problems. The wider the aspect ratio the less any runout in this area will be felt. It's the sidewall stiffness variation that transmits to

the chassis. Furthermore, tire sidewall variations and hidden constructional issues in the tire are not taken into consideration when unloaded runout is measured. Unloaded runout measurement can not indicate how much force is being created as a result of the runout since the tire stiffness can not be measured. Tire shoulders and other areas not measured may amplify or diminish the runout (and forces) when measured under load.

Summarization:

Force

The forces generated by a tire and wheel must be measured by placing a tire under load. Tire stiffness also plays a role in force calculations since this amplifies or diminishes the vibration effects of the runout measured. Road Force Measurement® uses loaded runout and tire stiffness measurements to calculate the actual force created by the loaded runout alone. For example, two tires with the same runout will differ in their ability to create vibration when a stiff tire sidewall is compared to a similar sized tire with a soft sidewall.

Runout

* Loaded – The entire footprint of a tire face is sampled faster and more accurately with a loaded roller. The shoulder areas in many cases have more effect on the vibration possible than unloaded eccentricity measured at a center location of the tire.

* Unloaded - For tire measurement this is problematic and limited in use since the tire has spring rate. It is limited in quantifying the vibration magnitude since typically a small area of the tire face is measured. For wheel measurement it is acceptable providing two measurements are taken at or near the bead seat area and then vector averaged to find the true low-point of the rim.

Important:

Runout measurement alone diminishes the ability to solve tire related vibration complaints. Unloaded tire runout ignores (a) constructional forces hidden inside the tire, (b) sidewall stiffness and 'spring rate' contributions and (c) it samples isolated areas of the tire instead of the entire footprint. Locating non-balance related vibration issues might very well diminish to a "game of chance". As a result the best possible ride quality is diminished and repair time will increase in frequency.

Road Force® Elite GSP9700 measures loaded runout and tire stiffness simultaneously so the magnitude of the vibration force that occur when the assembly is mounted on a vehicle is known.

Loaded Runout Measurement consisting of
Geometric (Visual) and Constructional (Hidden)
Eccentricities



Tire Stiffness Measurement



Road Force Measurement

7.4 Radial Force Variation vs. Unloaded Run Out

In the manufacturing community, tire uniformity is called radial force variation. The uniformity of most tires manufactured today is measured with a machine in accordance to SAE practice J332. This practice is widely used in the tire industry and describes tire testing equipment and procedures used to measure radial force variation of the tire. This practice stresses the importance of measuring force variation while the tire is under load and does not acknowledge unloaded runout measurement, for use in tire vibration testing.

Many tire assembly plants have large production lines to measure loaded tire force variation. Tires, which do not meet uniformity specifications, may be brought into specification through additional manufacturer's procedures called force grinding. Force grinding is done to improve radial force variation by removing small areas of rubber from the sides and footprint of the tread. Force grinding may not improve (and in some cases may increase) the unloaded runout measurement.

A tire with large amounts of unloaded radial runout may be vibration free while a tire with low unloaded radial runout may cause a ride disturbance. In many cases, tire companies will forego unloaded runout measurement since this information is not as valuable as tire force variation when it comes to analyzing the causes of tire ride disturbances.

In the past, when trying to resolve tire/wheel vibration concerns, service facilities were unable to measure tire force variation. The size and expense of the factory machines were cost prohibitive. In order to compensate for this lack of field service technology, many automotive and tire manufacturers have published service limits for unloaded runout in the tire/wheel assembly.

A standard industry practice has been to measure unloaded runout in the center of the tire tread using a relatively inexpensive gauge. However, this measurement has little relationship to the actual amount of ride disturbance felt in the vehicle. For example, a set of springs may have an unloaded height measurement of equal length, yet when compressed may create different forces at the same compressed height.

7.5 Road Force® Vibration Placed into Perspective

In the past, most tire/wheel assembly vibration was considered balance related. Because of this, tire service professionals tend to relate tire/wheel vibration in terms of balance weight. Road Force Measurement® will be best understood when related to the amount of balance weight required to cause a similar vibration in a wheel that rolls round under a load. In other words, “How much Road Force Measurement® creates a similar vibration caused by tire imbalance?”

Most tire service professionals and factory service manuals agree that residual static imbalance should not exceed 0.30 oz. on average size wheels and 0.60 oz. on larger light duty truck wheels.

Radial Force is determined by measuring loaded radial runout and tire stiffness. On an average passenger car tire/wheel assembly (1000psi spring rate), one thousandth of an inch (0.001”) of loaded radial runout is equivalent to approximately one pound of Road Force® Measurement.

Tests on a Chevrolet Lumina were performed using a chassis dynamometer in a Detroit test lab. The purpose of the test was to determine how much balance weight would be required to produce the same magnitude of force as a measured amount of loaded radial runout.

The tests were performed with the vehicle running at different speeds. The first test was at 50 miles per hour and the second test at 70 miles per hour.

At 50 mph, 30 pounds of road force caused .75 ounces (21 grams) of wheel imbalance. This is 2 1/2 times greater than the .30 ounce static imbalance limit.

At 70 mph, 30 pounds of road force caused 1.5 ounces (42 grams) of wheel imbalance. This is 5 times greater than the .30 ounce static imbalance limit.

7.6 StraightTrak® Lateral Force Measurement System

StraightTrak® Lateral Force Measurement

Although a vehicle’s suspension checks out to be acceptable, the tire pressure is correct, the vehicle suspension is properly aligned, and the tire/wheel assembly is perfectly round when rolling and balanced, the vehicle may still tend to pull or drift from a straight line. Frequently the cause of this pull is excessive difference in lateral force between the tires on the steer axle.

This optional feature measures the lateral forces of the tire/wheel assembly and suggests placement of each tire/wheel assembly (relative to the other tire/wheel assemblies) on the vehicle so that vehicle pull due to tire lateral forces may be minimized or eliminated.

Tire Pull Measurement and Correction

Even after tire/wheel assemblies have been balanced, correct inflation has been set, and suspension has been properly aligned, a vehicle may still pull from a straight line. The cause of this pull can be due to excessive difference in lateral tire force between the two tires on the steer axle.

The StraightTrak® Lateral Force Measurement (LFM) feature of the Road Force® Elite GSP9700 is configured to utilize lateral force measurement information taken from a set of vehicle tires. It provides suggested placements for the individual tires about the vehicle, such that the net tire pull between the two tires on the steer axle are minimized to improve or optimize the effects on vehicle handling.

When using StraightTrak® LFM, the basic machine cycle is the same, except that several additional tire revolutions have been added to the end of the cycle so that lateral force measurements can be taken. The only additional procedure necessary by the operator is to number, or “tag,” the tire assembly for identification and placement when balancing is completed.

The Road Force® Elite GSP9700 will provide the operator with suggested placement of the tire/wheel assemblies so that the net tire pull (lateral force) is minimized.

To maximize the effectiveness of StraightTrak® LFM, all other known sources of pull should first be reduced as much as possible. Improper and/or uneven tire inflation, excessive alignment angle variation side to side, and suspension/steering torque can also directly add to the potential for a vehicle to pull, and can even increase the rate at which the lateral forces in tires change over time.

Previously, diagnosis of such pull conditions involved the slow trial and error process of swapping tire/wheel assembly placements in a certain order, in the attempt of finding the least offensive placement. The amount of time involved in such a process is unpredictable and unfavorable for shops charging flat rates and for customers paying for labor by the hour.

While the StraightTrak® function should not replace fundamental diagnostic procedures, such as visual inspection of tread wear, inspection for brake drag, measurement of tire pressure and ride height, suspension check, alignment, and test driving, StraightTrak® has the potential to dramatically reduce the number of trial configurations and test drives.

What can be accomplished with StraightTrak® LFM?

Elimination or reduction of tire related drift/pull

Superior ride quality from increased vehicle straight-ahead stability

Prevention of problems or comebacks after rotations

Enhancement of steering stability and reduction in wandering

Reduction of driver fatigue due to pull

When should StraightTrak® LFM be used?

Tire mounting and balancing processes

Tire rotations

Alignment services

How is StraightTrak® LFM used?

Determine minimum lateral force offset on a steer axle to reduce/eliminate tire related pull conditions. The “least net tire pull” in most cases will yield the best results.

Diagnose residual pull symptoms with a road test. (In this case, the original placement of the tires and the associated tire net pull is important to use in order to determine the amount of offset on the new placement.) The “least net tire pull” placement may not be the best choice and in some cases “alternate placement” choices can be used to counteract other variables causing the vehicle to pull.

Theory

Automotive and light truck tires produce a lateral (or axial) force when rolling on a flat, smooth road. Lateral force is defined as the amount of directional side force generated

as the tire/wheel assembly rotates. The net sum difference in the lateral force between the two front steer tires may cause a vehicle to steer away from a straight line. Sources of lateral forces include tire conicity, ply steer, and other forces known together as **Total Lateral Force**. Traditional wheel balancers and static wheel alignment measuring systems cannot measure conditions caused by tire lateral forces. The automotive service industry has long been aware of tire-related vehicle lateral force conditions; however, no quantifiable method for diagnosis has existed for the service shop.

With the StraightTrak® Lateral Force Measurement (LFM) feature, the Hunter Road Force® Elite GSP9700 Series Road Force Measurement® System can measure the primary lateral forces generated by a rolling tire/wheel assembly. Using the load roller, it applies radial loads of up to 1400 pounds to the tire. The corresponding lateral forces produced between the tire and load roller are then measured. By rotating the tire/wheel assembly both clockwise and counter-clockwise, the system can calculate conicity values for a set of tires and then display net results from twelve possible tire combinations on the steer axle. With this information, technicians can place tires to minimize or eliminate pull. The Lateral Force measurement is automatically performed during the normal Road Force® measurement sequence.

Conicity

Conicity is the primary lateral tire force measurement that contributes to vehicle pull problems. When combined with other tire and vehicle variables, the vehicle may drive off line if the steering wheel is released. The steering wheel may be straight when the vehicle travels straight, but the driver must exert a force to the wheel to maintain the straight-ahead stability. This can result in driver annoyance, fatigue, and safety related concerns. Conicity is sometimes called “tire camber” and it affects the vehicle in a similar manner to suspension alignment angles.

Conicity forces will usually not cause a pull or drift issue when tires of similar values are mounted on the same vehicle. It is the net difference between the two tires on the steering axle that make the difference between a vehicle that rolls straight and one that drifts or pulls.

Conicity in tires may be caused when the radial belts vary from exact placement in the center of the tire carcass during construction. The sidewall to which the belts are placed closer will be stiffer (and thus taller) than the opposite side. This produces a cone shaped tire when loaded.

Conicity in tires will also be affected by tire wear, therefore conicity values typically change during a tire’s life.

Plysteer

Plysteer induces a dog-tracking attitude of the vehicle. When large net plysteer variations on an axle are encountered, the steering wheel will change position and possibly end up crooked to maintain a straight direction of travel. The vehicle, however, will not necessarily drift or change lanes when the steering wheel is released. The driver at the steering wheel exerts no correction force. The Road Force® Elite GSP9700 measures, but does not display and correct for plysteer.

Net Tire Pull

Net Tire Pull is the measurement displayed by the Road Force® Elite GSP9700 to allow the operator to determine the best tire placement about the vehicle. It is defined as the difference between the lateral forces measured on the front steer axle. In most cases, a tire's pull value is of little concern when placed on the rear axle and does not affect the straight-ahead stability of the vehicle.

The measured loaded tire diameter (displayed for each tire/wheel assembly) can also affect the pull condition. A significant difference in these measurements may indicate under/over inflation in a tire or a mismatched set of tires.

Another common factor that can affect steering pull or drift in relation to the tires is the variation in air pressure of the two tires when compared side to side on a given axle.

8. Glossary

Amplitude (Magnitude)

The amount of force or the intensity of the vibration.

Back Coning

When the wheel requires the cone to center the wheel on the balancer's shaft from the backside, primarily due to the chamfer of the wheel. Also referred to as Back-Cone Mounting.

Backspacing

The distance measured from the mounting face to the back edge of the wheel.

BDC

The abbreviation for bottom dead center also referred to as 6 o'clock.

Bead seating

The process of seating the tire to the rim bead seats. Bead seating preferably occurs just after the tire and rim have been assembled, but may gradually change and optimize over a longer period. If loaded with the Road Force® Elite GSP9700 load roller or driven, the position of the bead may optimize or always remain seated improperly, unless the tire is demounted, lubricated, and remounted. However, the load force and its' relatively short duration will not necessarily solve defective mounting of the tire bead seat to the rim seat.

Blinding and Rounding

Blinding is a set amount of imbalance required before an indication of imbalance is displayed. Rounding sets the weight increments to specific amounts, such as tenths, or quarters, etc.

Bolt Pattern Circle

The diameter of an imaginary circle drawn through the center of each lughole, and virtually always on the same centerline as the hub bore of the wheel.

CenteringCheck

Hunter feature that ensures the wheel is properly centered when mounted on the balancer.

Couple Balance

A procedure that corrects the imbalance in radial movement.

Dynamic Balance

A procedure that balances the wheel assembly by applying correction weights in two planes so that up and down imbalance and side-to-side imbalance are eliminated.

eCa™

A method automatically adjusting balancer transducer calibration.

Force Matching™

A method of aligning the high spot of the tire's radial force variation with the low spot of rim runout to decrease rolling vibration in the wheel assembly.

Forced Vibration

Vibrates when energy is applied.

Free Vibration

Continues to vibrate after the outside energy stops.

Frequency

The number of disturbances that occur per unit of time.

Front Coning

When the wheel requires the cone to center the wheel on the balancer's shaft from the front. Also referred to as Front-Cone Mounting.

Harmonic

A vibration that is identified by the number of occurrences per revolution. For example, a 1st harmonic vibration has a once per revolution vibration component.

Hertz

A unit of frequency: one disturbance per second.

Hub Centric

The wheel is centered using the center hole of the wheel.

Inflation Station

A feature on models of the Road Force® Elite GSP9700 that automatically inflates or deflates tires to a predetermined air pressure.

Lateral Runout

The amount of side-to-side movement as the tire/wheel assembly rotates.

Load Roller

Feature of balancers that measure Road Force® measurements. The load roller runs perpendicular to the tire and applies up to 1400 pounds of force to simulate road conditions.

Lug Centric

The wheel is centered using the lug holes rather than the wheel center hole.

Magnitude (Amplitude)

The amount of force or the intensity of the vibration.

MatchMaker®

Allows the operator to match up four identical tires on identical rims, to achieve the optimal combination of match mounting.

Natural Frequency

The point at which an object will vibrate the easiest.

Order

The number of disturbances per cycle (rotation). For example, a 1st order vibration occurs once per cycle, and a 2nd order vibration occurs twice per cycle.

P, P/SUV, LT

“P Tires” refers to passenger tires, “LT Tires” refers to light truck tires, and “P/SUV Tires” refers to P-Rated sport utility vehicle tires.

Patch Balance

Method of balancing that balances weighted rubber patches applied to the inside of a tire.

PAX

A specifically designed wheel/tire assembly that does not use the traditional rim lip/bead design. PAX assemblies require adhesive or patch balancing.

Phase

The position of a vibration cycle relative to another vibration cycle in the same time reference.

Phasing

The cycle pattern of two or more vibrations that overlap and combine to increase the overall magnitude.

Pressure Ring

The accessory used to prevent the wing nut from contacting the wheel when on the balancer shaft.

Quick-Thread®

Motor assisted threading of the wing nut for quick installation and removal.

Radial Force Variation (RFV)

A term describing a measurement of the tire uniformity, under load, measuring the variation of the load acting toward the tire center.

Radial Runout

A condition where the tire and wheel assembly is slightly out of round forcing the spindle to move up and down as the vehicle rolls along a smooth surface.

Resonance

The point where a vibrating component's frequency matches the natural frequency of another component.

Responding Component

The noticeable component that is vibrating.

Road Force®

A change in the force between the wheel and the axle while rotating under a load. Discrepancy in road force can cause a vibration although the tire and rim may be perfectly round and the tire is balanced.

Road Force Measurement®

A measurement of the wheel assembly as would be found from an actual road test of a vehicle. The Road Force® Elite GSP9700 is equipped with a load roller to

take the Road Force Measurement®. The load roller places up to 1400 pounds of force on the spinning tire, and automatically measures the effects of loaded runout and tire stiffness to emulate tire/wheel assembly force variation. Loaded runout of rim and tire stiffness calculated equals the Road Force Measurement®.

Road Force® Variation

A change in force exerted on the axle by the tire/wheel assembly while rotating under load. Units of measurement are in pounds, Newton's, etc.

Runout

The side-to-side movement of a wheel as measured from its true center.

Servo-Stop

The ability to locate varying positions of the tire/wheel assemblies and hold the position in place while correctional weights or OE-Matching marks are applied.

SmartWeight® Balancing Technology

SmartWeight® measures the forces placed on a wheel and balances in an effort to reduce those forces, thus saving weight, time, and money.

Source Component

A component causing another object to vibrate, such as a tire/wheel assembly.

SmartScan™

Feature using inner and outer cameras that measures runout on every spin, determines spoke and weight plane location, as well as the wheel weight mode (either clip or tape).

SpeedClamp™

Pneumatically-powered automatic wheel clamping device.

Spindle-Lok®

A feature that locks the spindle in place by depressing the foot pedal.

Split Weight®

Feature designed to reduce single heavy amounts of weight by dispersing the corrective weight over a wider area.

Static Balance

A procedure that balances the wheel assembly using only a single weight plane so that up and down imbalance is eliminated.

StraightTrak®

Balancer feature which helps designate where tires should be installed on a vehicle for optimum ride and handling.

TDC

An abbreviation for top dead center. Also referred to as 12 o'clock.

Torque Sensitive Vibration

The vibration occurs when accelerating, decelerating, or applying the throttle.

Total Indicated Reading (T.I.R.)

Data measurements taken by the load roller (measured in lbs. or kg) or Dataset® Arms (measured in inches or millimeters) representing the actual runout measured. The T.I.R. data represents the difference in value between the highest and lowest value measured.

TruWeight™

A method calculating and displaying exact placement of balance weights on a wheel.

Vibration

A shaking or trembling, which may be heard or felt.

Weightsaver® Feature

Weightsaver® is the percentage of maximum shimmy allowed. The larger the percentage, the greater the weight savings.

Wheel Diameter

Dimension measured on the inside of the rim at the bead seats.

Wheel Offset

The measured distance between the mounting face of the wheel and the centerline of the rim.

Wheel Width

Dimension measured on the inside of the rim between the bead seats.



Hunter Research and Training Center



HUNTER TRAINING

Hunter operates the most advanced, up-to-date Training Center in the industry today.

The courses have been designed to meet the needs of new and experienced technicians who want to increase their mechanical and diagnostic capabilities. The low student-teacher ratio (average 7 to 1) and the emphasis on "hands-on" training (70% time in shop) create an excellent learning environment.

Highlights of the Hunter Training Center include:

- ✓ An instruction staff with years of shop, field, and teaching experience.
- ✓ Fully-equipped service bays.
- ✓ Classrooms equipped with modern teaching aids.
- ✓ The most up-to-date wheel alignment, balancing service, and brake equipment on the market today

Classes Available

- ❑ **Align 1** (Basic Alignment Theory and Practice) - 3 day / 24 hours
- ❑ **Align 2** (Advanced theory / Aftermarket Adjustment) - 2 day / 16 hours
- ❑ **Align 3** (Advanced Diagnostics and OEM Procedures) - 2 day / 16 hours
- ❑ **Performance Tire** (Basic and Advanced Tire Changing) - 1 day 8 hours
- ❑ **Road Force® / GSP9700 Certification** - 2 day / 16 hours
- ❑ **Rolling Smooth** (Basic & Advanced vibration theory) - 1 day / 8 hours
- ❑ **Heavy-Duty Truck Alignment 1** (Fundamental Alignment) - 3 day / 24 hours
- ❑ **Heavy-Duty Truck Alignment 2** (Advanced Alignment) - 2 day / 16 hours

HUNTER
Engineering Company